



LIGHTING



INDEX

SAGITTER

- 4** Led Moving Heads
- 7** Acl Leds
- 12** Architectural Leds
- 21** Stage Leds
- 37** Led Projectors
- 41** Cob Projectors
- 44** Led Battery Projectors
- 48** Controllers
- 51** Ambient Effects

SDJ

- 56** Led Moving Heads
- 65** Led Projectors
- 76** Stage Leds
- 80** Led Battery Projectors
- 82** Led Bars
- 88** Led Pixel
- 92** Led Kits
- 97** Controllers
- 105** Ambient Effects

genuine Accessories

- 115** Pro Fluids
- 116** Lamps
- 118** DMX Cables
- 119** Cables
- 120** Cablecross
- 122** Clamps
- 123** Modula Series
- 130** Flightcases
- 131** Accessories

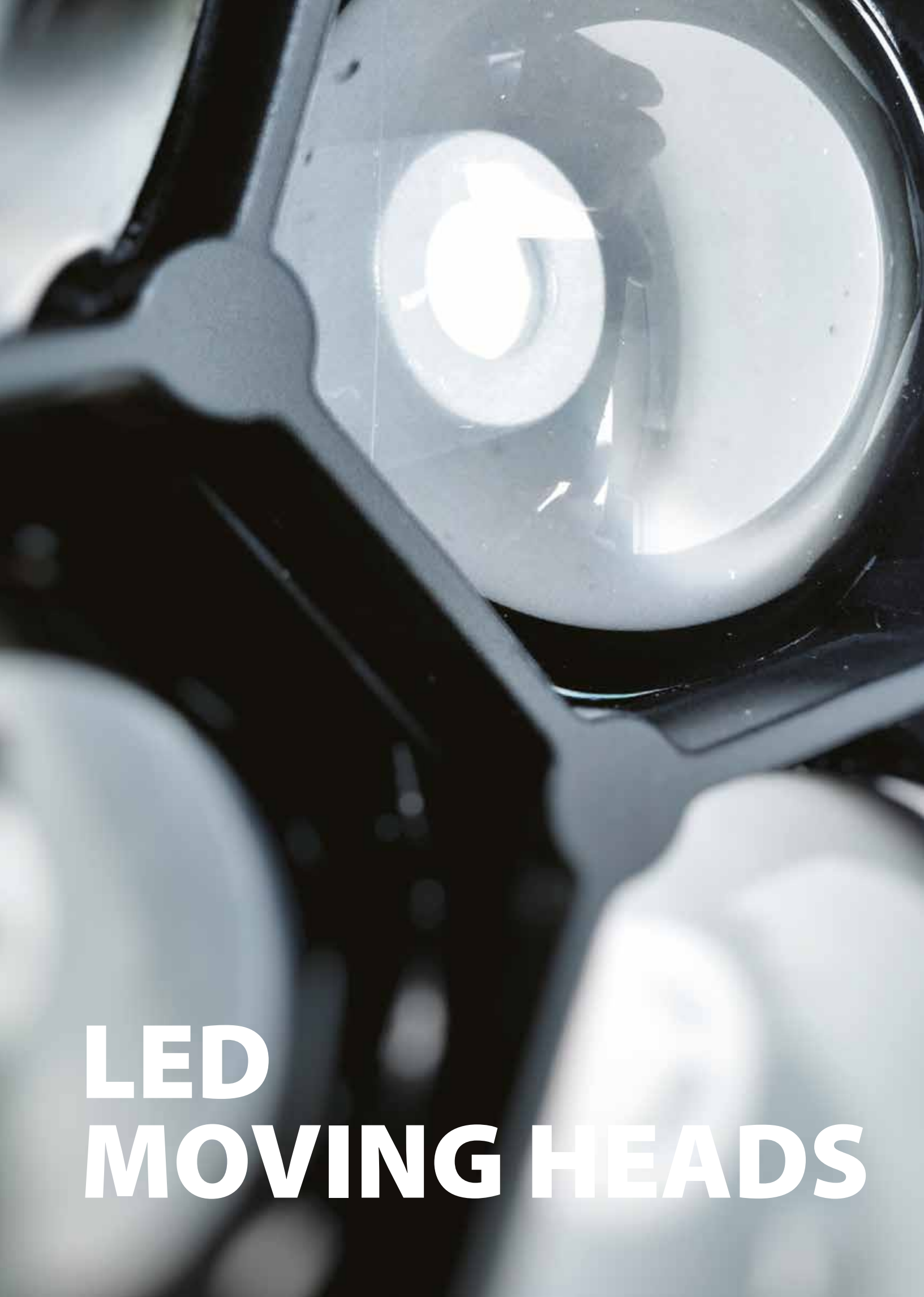

**LED
MOVING HEADS**



LED MOVING HEADS

QUARTZ 300



SG QUARTZ300 - PRODUCT CODE

SG CASEQUARTZ300 - CASE (2X SG QUARTZ300)

SG CASEQUARTZ300X4 - CASE (4X SG QUARTZ300)

SG QUARTZ300KIT - KIT (2X SG QUARTZ300 + 1X SG CASEQUARTZ300)

LIGHT SOURCE

- 19x15W RGBW Full Color led
- LED lifespan: >50.000h
- Led refresh frequency: >400Hz anti-flicker

OPTIC SYSTEM

- Beam angle: motorized zoom from 8° to 62°
- Luminous flux: 8600Lux (5m – full ON – 8°) / 800Lux (5m – full ON – 62°)

COLOR SYSTEM

- RGBW full color mixing
- Infinite chromatic possibilities

EFFECTS

- Linear dimmer 0-100%
- Electronic high speed strobe from 1 to 20 flashes/s, adjustable speed
- Random strobe and pulse effect with adjustable speed
- Single Pixel control
- Color macros and Pixel macros selectable from dmx

CONTROL AND PROGRAMMING

- 3 different dmx configurations: 14/20/92 channels
- Protocol USITT DMX 512
- Pan&Tilt 8/16 bit resolution selectable
- Master/Slave mode
- Reset via dmx

STRUCTURE AND CABINET

- Black metal housing and plastic covers with high resistance
- LCD color graphic display
- PAN 630°/540°/360° selection and TILT 270°/180°/90° selection
- Mounting points: 1 pair of ¼ turn lock omega holders
- Automatic Pan&Tilt repositioning after accidental movement
- 3 poles XLR in/out dmx signal connections
- IP20 protection grade
- Forced air fan cooling system with electronic control

POWER SUPPLY

- Input Voltage: AC~100-240V 50/60Hz
- Switching power supply unit
- Max power: 350W @ 230VAC
- Power in/out connection with Powercon sockets
- Power supply cable included

WEIGHT AND DIMENSIONS

- Net weight: 11,5 kg
- Dimensions: 420x205x450 mm

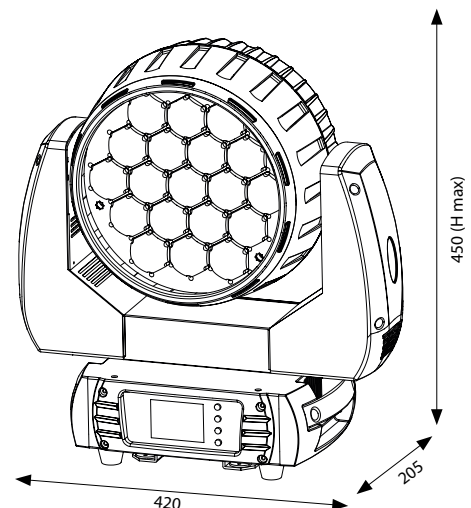

LED MOVING HEADS

QUARTZ 100



SG QUARTZ100 - PRODUCT CODE
SG CASEQUARTZ100 - CASE (4X SG QUARTZ100)

LIGHT SOURCE

- 7x15W RGBW Full Color led
- LED lifespan: >50.000h
- Led refresh frequency: >400Hz anti-flicker

OPTIC SYSTEM

- Beam angle: motorized zoom from 8° to 62°
- Luminous flux: 2167Lux (5m – full ON – 8°) / 154Lux (5m – full ON – 62°)

COLOR SYSTEM

- RGBW full color mixing
- Infinite chromatic possibilities

EFFECTS

- Linear dimmer 0-100%
- Electronic high speed strobe from 1 to 20 flashes/s, adjustable speed
- Random strobe and pulse effect with adjustable speed
- Single Pixel control
- Color macros and Pixel macros selectable from dmx

CONTROL AND PROGRAMMING

- 3 different dmx configurations: 14/20/44 channels
- Protocol USITT DMX 512
- Pan&Tilt 8/16 bit selectable resolution
- Master/Slave mode
- Reset via dmx

STRUCTURE AND CABINET

- Black metal housing and plastic covers with high resistance
- LCD color graphic display
- PAN 630°/540°/2700° selection and TILT 270°/180°/90° selection
- Mounting points: 1 pair of ¼ turn lock omega holders
- Automatic Pan&Tilt repositioning after accidental movement
- 3 poles XLR in/out dmx signal connections
- IP20 protection grade
- Forced air fan cooling system with electronic control

POWER SUPPLY

- Input Voltage: AC~100-240V 50/60Hz
- Switching power supply unit
- Max power: 110W @ 230VAC
- Power in/out connection with Powercon sockets
- Power supply cable included

WEIGHT AND DIMENSIONS

- Net weight: 6,2 kg
- Dimensions: 290x160x350 mm

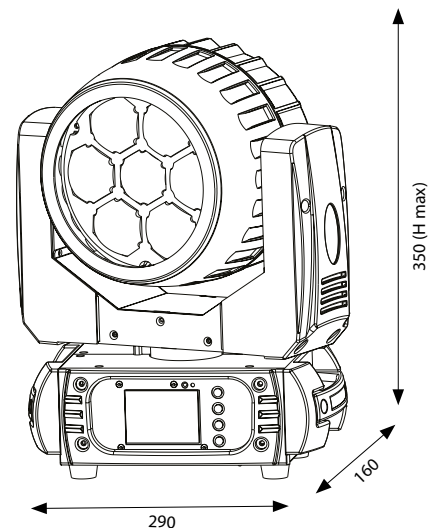



ACL LEDs

ACL BAR 10

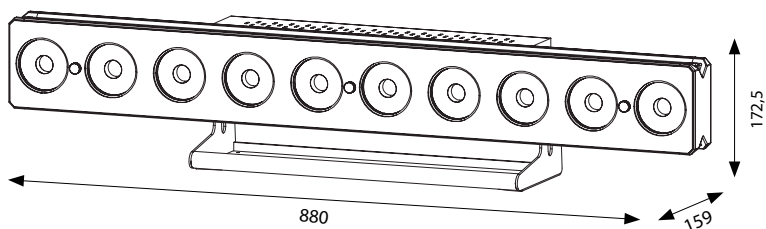

SG ACLBAR10 - PRODUCT CODE
SG CASEACLBAR - CASE (4X SG ACLBAR10)

LIGHT SOURCE

- 10x15W led RGBW Full Color
- LED lifespan: > 50.000h
- LED refresh frequency: > 400Hz flicker-free

OPTIC SYSTEM

- Beam Angle: 4°

COLOR SYSTEM

- LED source RGBW Full color
- Infinite chromatic possibilities

EFFECTS

- Linear dimmer 0-100%
- Adjustable strobe effect
- Color macros selectable via DMX
- Single pixel control
- Removable frost filter included

CONTROL AND PROGRAMMING

- 5 DMX configurations available: 4/6/8/40/44 channels
- Protocol USITT DMX 512
- Protocol Art-Net
- Master/Slave mode
- Auto mode
- Sound mode

STRUCTURE AND CABINET

- Die cast aluminium and metal housing, black color
- Blue LCD graphic display
- "Light up" positioning with adjustable angle
- IP rating: IP20
- DMX IN/OUT connectors 3/5 poles
- Art-Net connectors IN/OUT
- Convection cooling system without fans

POWER SUPPLY

- Input Voltage: AC~100-240V, 50/60 Hz
- Switching power supply unit
- Max power: 160W @ 230VAC
- Power input with PowerCON connector IN/OUT
- Power supply cable 1mt included

WEIGHT AND DIMENSIONS

- Net weight: 9,4 kg
- Dimensions: 880x159x172,5 mm



SG ACLBAR5 - PRODUCT CODE
SG CASEACLBAR - CASE (4X SG ACLBAR5)

LIGHT SOURCE

- 5x15W led RGBW Full Color
- LED lifespan: > 50.000h
- LED refresh frequency: > 400Hz flicker-free

OPTIC SYSTEM

- Beam Angle: 4°

COLOR SYSTEM

- LED source RGBW Full color
- Infinite chromatic possibilities

EFFECTS

- Linear dimmer 0-100%
- Adjustable strobe effect
- Color macros selectable via DMX
- Single pixel control
- Removable frost filter included

CONTROL AND PROGRAMMING

- 5 DMX configurations available: 4/6/8/20/24 channels
- Protocol USITT DMX 512
- Protocol Art-Net
- Master/Slave mode
- Auto mode
- Sound mode

STRUCTURE AND CABINET

- Die cast aluminium and metal housing, black color
- Blue LCD graphic display
- "Light up" positioning with adjustable angle
- IP rating: IP20
- DMX IN/OUT connectors 3/5 poles
- Art-Net connectors IN/OUT
- Convection cooling system without fans

POWER SUPPLY

- Input Voltage: AC~100-240V, 50/60 Hz
- Switching power supply unit
- Max power: 85W @ 230VAC
- Power input with PowerCON connector IN/OUT
- Power supply cable 1mt included

WEIGHT AND DIMENSIONS

- Net weight: 6 kg
- Dimensions: 440x160x172,5 mm

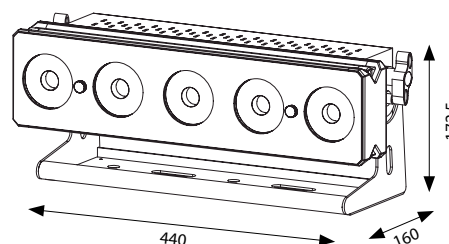

ACL LEDS

ACL PAR 1



SG ACLPAR1 - PRODUCT CODE

LIGHT SOURCE

- 1x15W led RGBW Full Color
- LED lifespan: > 50.000h
- LED refresh frequency: > 400Hz flicker-free

OPTIC SYSTEM

- Beam Angle: 4°

COLOR SYSTEM

- LED source RGBW Full color
- Infinite chromatic possibilities

EFFECTS

- Linear dimmer 0-100%
- Adjustable strobe effect
- Color macros selectable via DMX
- Two removable frost filters included

CONTROL AND PROGRAMMING

- 3 DMX configurations available: 4/6/7 channels
- Protocol USITT DMX 512
- Master/Slave mode
- Auto mode
- Sound mode
- Remote controller included

STRUCTURE AND CABINET

- Die cast aluminium housing, black color
- OLED display
- "Light up" positioning with adjustable angle - double bracket
- IP rating: IP20
- DMX IN/OUT connectors 3 poles
- Convection cooling system without fans

POWER SUPPLY

- Input Voltage: AC~100-240V, 50/60 Hz
- Switching power supply unit
- Max power: 16W @ 230VAC
- Power input with PowerCON connector IN/OUT
- Power supply cable 1mt included

WEIGHT AND DIMENSIONS

- Net weight: 1,2 kg
- Dimensions: 134,5x172,25x202,5 mm

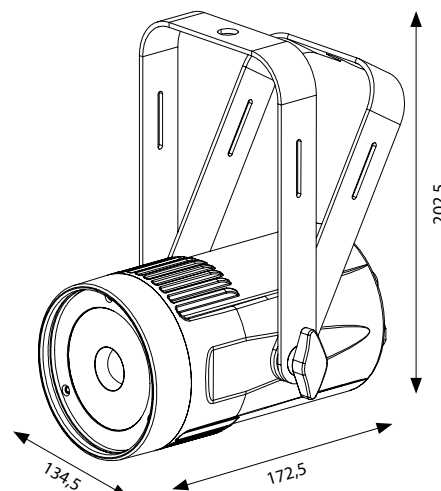



ACL PAR BATTERY



NEW

SG ACLPARBATBKC - PRODUCT CODE BLACK VERION
SG ACLPARBATWHC - PRODUCT CODE WHITE VERION
SG ACLPARBAG - SOFT BAG (6X SG ACLPARBATBKC)
SG ACLPARCHR - CHARGER FOR 6X SG ACLPARBATBKC

LIGHT SOURCE

- 1x15W led RGBW Full Color
- LED lifespan: > 50.000h
- LED refresh frequency: > 400Hz anti flicker

OPTIC SYSTEM

- Beam Angle: 4°
- Luminous flux: 2300 lux @ 5m (full on max power)

COLOR SYSTEM

- LED source RGBW Full color
- Infinite chromatic possibilities

EFFECTS

- Linear dimmer 0-100%
- Adjustable strobe effect
- Color macros selectable via DMX
- Two removable frost filters included

CONTROL AND PROGRAMMING

- 4 DMX configurations available: 1/4/6/7 channels
- Protocol USITT DMX 512
- Built-in DMX wireless transceiver by Wireless Solution
- Master/Slave mode
- Auto mode with 3 different programs with adjustable strobe and speed
- Sound mode with adjustable sensitivity
- Remote controller included

STRUCTURE AND CABINET

- Die cast aluminium housing
- Blue LCD graphic display
- "Light up" positioning with adjustable angle
- IP rating: IP20
- Convection cooling system without fans

POWER SUPPLY

- Input Voltage: 12-15VDC – 2A min, for normal working and battery recharge
- Max power: 24W
- Internal rechargeable battery: 11,1VDC
- Capacity: 2,6Ah
- Runtime battery: ~2/4/6/8h (Adjustable max power)
- Charging cycle: ~5h (Projector off)
- Power adapter included

WEIGHT AND DIMENSIONS

- Net weight: 1,2 kg
- Dimensions: 130x180x160 mm

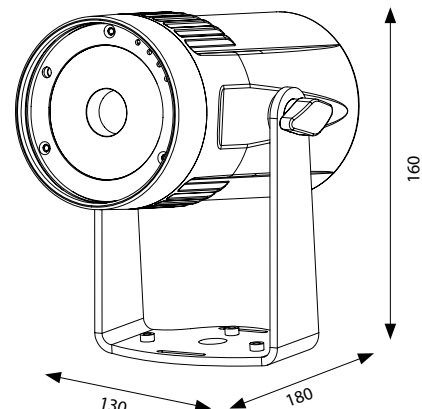



ARCHITECTURAL LEDS

ARCHITECTURAL LEDS

QUARIUX

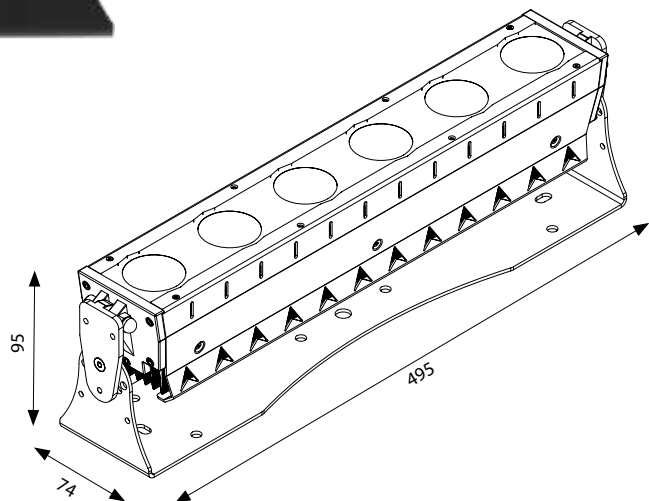

- SG QUARIUXRGB** - PRODUCT CODE RGB VERSION
- SG QUARIUXRGBZ** - PRODUCT CODE RGB VERSION ZOOM
- SG QUARIUXRGBW** - PRODUCT CODE RGBW VERSION
- SG QUARIUXRGBWZ** - PRODUCT CODE RGBW VERSION ZOOM
- SG QUARIUXRGBL** - PRODUCT CODE RGB-LIME VERSION
- SG QUARIUXRGBLZ** - PRODUCT CODE RGB-LIME VERSION ZOOM
- SG QUARIUXWW** - PRODUCT CODE WARM WHITE VERSION
- SG QUARIUXCW** - PRODUCT CODE COLD WHITE VERSION
- SG QUARIUXVW** - PRODUCT CODE VARIABLE WHITE VERSION
- SG CASEQUARIUX** - CASE (6x SG QUARIUX)

LIGHT SOURCE

- 6x40W COB led
- LED lifespan: >50.000h
- LED refresh frequency: >500Hz flicker free

OPTIC SYSTEM

- Beam angle: 12° (standard)
- SSZ: Solid State Zoom (from 12° to 90°) upon request
- Optional optic: 24° - 48° - 80° - 12°x90° (asymmetric)

COLOR SYSTEM

- 3 in 1 led source RGB Full Color (standard)
- Available possibilities: RGBW – RGBL – WW – CW – VW
- Macro colors selectable via DMX
- Halogen and CMY Simulation

EFFECTS

- Linear dimmer 16 bit 0 - 100%
- Electronic strobo 1-20 flash/s adjustable speed
- Overboost Blinder

CONTROL AND PROGRAMMING

- DMX configurations availables: 1/2/3/5/7/10 channels
- 4 dimmer curves selectable
- Protocol USITT DMX 512
- Master/Slave mode
- Presetted macro colors with speed regulation
- Static Color: static reproduction of one color
- Touch pad with led indicators
- Integrated wireless DMX

STRUCTURE

- Aluminium structure, available in black or customizable with other colors
- High tightness Lexan, resistant to cuts and perforations
- Fast coupling system
- Bracket for anchoring and ground support
- IP rating: IP 67
- Convection cooling system without fans
- Optional barndoor
- Operating temperature -20°C ~ 40°C

POWER SUPPLY

- Input Voltage: ~88-264Vac 47/63Hz
- Universal switching power supply
- Double temperature control
- Max power: 200W @ 230VAC
- IN/OUT power connection

WEIGHT AND DIMENSIONS

- Net weight: 5,7 kg
- Dimension: 495x74x95 mm

ARCHITECTURAL LEDES

IP LED 32C DL



NEW

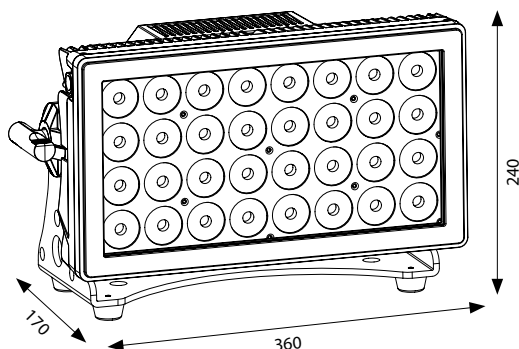

SG IPLED32CDL - PRODUCT CODE
SG CASEIPLED32C - CASE (4X SG IPLED32CDL)
SG IPLED32CBN - BARNDOOR

LIGHT SOURCE

- 32x12W led RGBWA-UV Full Color
- LED lifespan: > 50.000h
- LED refresh frequency: > 400Hz flicker-free

OPTIC SYSTEM

- Beam Angle: 25°
- Luminous flux: 2500lux @ 5m (full on)

COLOR SYSTEM

- LED source RGBWA-UV Full color
- Infinite chromatic possibilities

EFFECTS

- Linear dimmer 0-100%
- Adjustable strobe effect
- Color macros selectable via DMX
- 8 sectors control

CONTROL AND PROGRAMMING

- 6 DMX configurations available: 6/10/11/16/48/96 channels
- Key lock password for display lock
- Protocol USITT DMX 512
- Built-in Wireless DMX by Wireless Solution
- Master/Slave mode
- Static color mode
- Auto mode with 4 different programs selectable from the display, with speed adjustment
- Color mode with 63 different pre-programmed color macros
- White balance control

STRUCTURE AND CABINET

- Die cast aluminium housing
- Blue LCD graphic display
- Front tempered glass
- "Light up" positioning with adjustable angle
- IP rating: IP65
- DMX 3-poles XLR IP65 IN/OUT connectors
- Low Noise controlled forced ventilation cooling system
- Frost filter included

POWER SUPPLY

- Input Voltage: AC~100-240V, 50/60 Hz
- Switching power supply unit
- Max Power: 390W @ 230VAC
- IP65 Powercon True ONE IN/OUT connectors

WEIGHT AND DIMENSIONS:

- Net weight: 8,2 kg
- Dimensions: 360x170x240 mm

ARCHITECTURAL LEDS

IP LED 24C



SG IPLED24C - PRODUCT CODE

LIGHT SOURCE

- 24x8W led RGBW Full Color
- LED lifespan: > 50.000h
- LED refresh frequency: > 400Hz flicker-free

OPTIC SYSTEM

- Beam Angle: 25°

COLOR SYSTEM

- LED source RGBW Full color
- Infinite chromatic possibilities

EFFECTS

- Linear dimmer 0-100%
- Adjustable strobe effect
- Color macros selectable via DMX

CONTROL AND PROGRAMMING

- 3 DMX configurations available: 3/6/7 channels
- Key lock password for display lock
- Protocol USITT DMX 512
- Master/Slave mode
- Auto mode
- Remote controller included

STRUCTURE AND CABINET

- Die cast aluminium housing
- Blue LCD graphic display
- Front tempered glass
- "Light up" positioning with adjustable angle
- IP rating: IP65
- DMX IN/OUT connectors IP65
- Convection cooling system without fans

POWER SUPPLY

- Input Voltage: AC~100-240V, 50/60 Hz
- Switching power supply unit
- Max power: 200W @ 230VAC
- IN/OUT power connection IP65

WEIGHT AND DIMENSIONS

- Net weight: 8,4 kg
- Dimensions: 288x130x325,6 mm

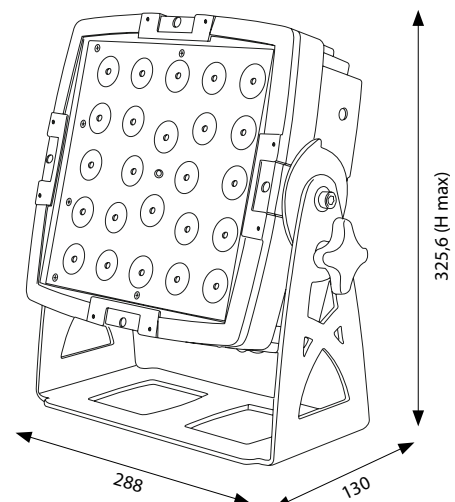

ARCHITECTURAL LEDES

IP LED 9C



SG IPLED9C - PRODUCT CODE

LIGHT SOURCE

- 9x8W led RGBW Full Color
- LED lifespan: > 50.000h
- LED refresh frequency: > 400Hz flicker-free

OPTIC SYSTEM

- Beam Angle: 25°

COLOR SYSTEM

- LED source RGBW Full color
- Infinite chromatic possibilities

EFFECTS

- Linear dimmer 0-100%
- Adjustable strobe effect
- Color macros selectable via DMX

CONTROL AND PROGRAMMING

- 3 DMX configurations available: 3/6/7 channels
- Key lock password for display lock
- Protocol USITT DMX 512
- Master/Slave mode
- Auto mode
- Remote controller included

STRUCTURE AND CABINET

- Die cast aluminium housing
- LCD graphic display
- Front tempered glass
- "Light up" positioning with adjustable angle
- IP rating: IP65
- DMX IN/OUT connectors IP65
- Convection cooling system without fans

POWER SUPPLY

- Input Voltage: AC~100-240V, 50/60 Hz
- Switching power supply unit
- Max power: 80W @ 230VAC
- IN/OUT power connection IP65

WEIGHT AND DIMENSIONS

- Net weight: 3,8 kg
- Dimensions: 202x122,3x222 mm

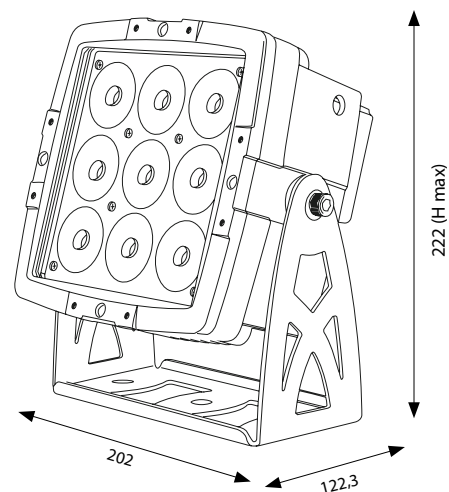



ARCHITECTURAL LEDS

IP LED BAR 12C

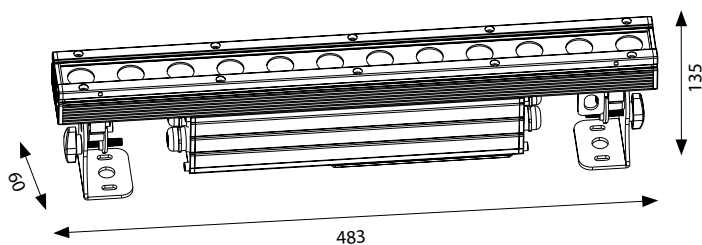

SG IPLEDBAR12C - PRODUCT CODE

LIGHT SOURCE

- 12x8W led RGBW Full Color
- LED lifespan: > 50.000h
- LED refresh frequency: > 400Hz flicker-free
- Optic system
- Beam Angle: 15°
- Luminous flux: 1221 lux @3mt

COLOR SYSTEM

- LED source RGBW Full color
- Infinite chromatic possibilities

EFFECTS

- Linear dimmer 0-100%
- Adjustable strobe effect
- Color macros selectable via DMX
- 2 sector control system

CONTROL AND PROGRAMMING

- 5 DMX configurations available: 3/4/7/8/10 channels
- Protocol USITT DMX 512
- Master / Slave mode
- Static color mode
- Automatic mode with 5 different programs selectable from the display
- Effect mode with 8 different programs selectable from the display
- Color mode with 6 different programs selectable from the display
- 4 dimmer curve

STRUCTURE AND CABINET

- Die cast aluminium housing
- OLED display
- Soft touch button
- Front tempered glass
- Antiglare blade (included)
- "Light up" positioning with adjustable angle
- IP rating: IP65
- DMX IN/OUT connectors IP65
- Convection cooling system without fans

POWER SUPPLY

- Input Voltage: AC~100-240V, 50/60 Hz
- Switching power supply unit
- Max power: 96W @ 230VAC
- IN/OUT power connection IP65

WEIGHT AND DIMENSIONS

- Net weight: 3,3 kg
- Dimensions: 483x60x135 mm

ARCHITECTURAL LEDES

IP LED BAR 24C

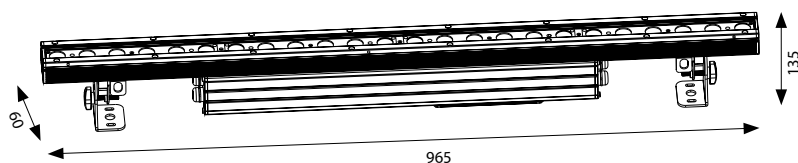

SG IPLEDBAR24C - PRODUCT CODE

LIGHT SOURCE

- 24x8W led RGBW Full Color
- LED lifespan: > 50.000h
- LED refresh frequency: > 400Hz flicker-free

OPTIC SYSTEM

- Beam Angle: 15°
- Luminous flux: 1221 lux @3mt

COLOR SYSTEM

- LED source RGBW Full color
- Infinite chromatic possibilities

EFFECTS

- Linear dimmer 0-100%
- Adjustable strobe effect
- Color macros selectable via DMX
- 4 sector control system

CONTROL AND PROGRAMMING

- 7 DMX configurations available: 3/4/7/8/10/16/20 channels
- Protocol USITT DMX 512
- Master / Slave mode
- Static color mode
- Automatic mode with 5 different programs selectable from the display
- Effect mode with 8 different programs selectable from the display
- Color mode with 6 different programs selectable from the display
- 4 dimmer curve

STRUCTURE AND CABINET

- Die cast aluminium housing
- OLED display
- Soft touch button
- Front tempered glass
- Antiglare blade (included)
- "Light up" positioning with adjustable angle
- IP rating: IP65
- DMX IN/OUT connectors IP65
- Convection cooling system without fans

POWER SUPPLY

- Input Voltage: AC~100-240V, 50/60 Hz
- Switching power supply unit
- Max power: 192W @ 230VAC
- IN/OUT power connection IP65

WEIGHT AND DIMENSIONS

- Net weight: 5,6 kg
- Dimensions: 965x60x135 mm



ARCHITECTURAL LEDS

IP LED MICRO BAR 54C



NEW



SG IPLEDMCBAR54C - PRODUCT CODE

LIGHT SOURCE

- 54x3W led RGB
- LED lifespan: > 50.000h
- LED refresh frequency: > 400Hz flicker-free

OPTIC SYSTEM

- Beam Angle: 60x10°

COLOR SYSTEM

- LED source RGB
- Infinite chromatic possibilities

EFFECTS

- Linear dimmer 0-100%
- Adjustable strobe effect
- Color macros selectable via DMX

CONTROL AND PROGRAMMING

- 5 DMX configurations available: 1/3/4/7/10 channels
- Protocol USITT DMX 512
- Master/Slave mode
- Auto mode with 10 different programs selectable from the display with speed adjustment
- Static color mode with strobe adjustment
- Color mode with 55 pre-programmed color macros

STRUCTURE AND CABINET

- Die cast aluminium housing
- Color LCD display
- Front tempered glass
- "Light up" positioning with adjustable angle
- IP rating: IP65
- Power and DMX IN/OUT connector IP65
- Convection cooling system without fans

POWER SUPPLY

- Input Voltage: AC~100-240V, 50/60 Hz
- Switching power supply unit
- Power and DMX IN/OUT connector IP65

WEIGHT AND DIMENSIONS

- Net weight: 1,9 kg (bar)
- Dimensions: 395x55x85 mm (bar)

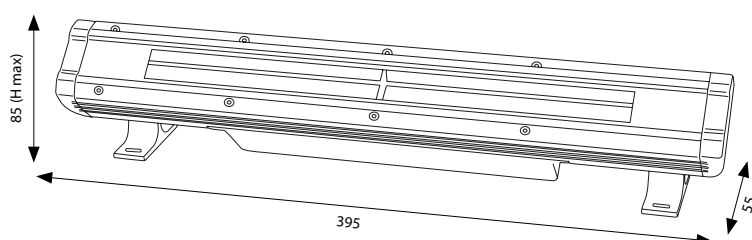

IP LED BAR 8 BATTERY

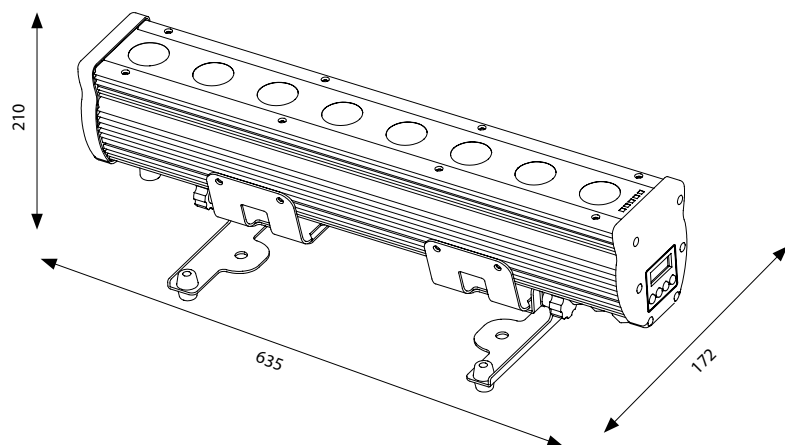

SG IP LED BAR 8 BATTERY - PRODUCT CODE
SG CASE IP LED BAR 8 BATTERY - CASE WITH CHARGE SYSTEM (4X SG IP LED BAR 8 BATTERY)

LIGHT SOURCE

- 8x10W led RGBW Full Color
- LED lifespan: >50,000h
- LED refresh frequency: >400Hz anti-flicker

OPTIC SYSTEM

- Beam angle: 10° x 40°
- Luminous flux: 600 lux @5mt (full on)

COLOR SYSTEM

- LED source 4 in 1 RGBW Full Color
- Infinite chromatic possibilities and colour temperature control

EFFECTS

- Linear Dimmer 0-100%
- Electronic strobe: 1-20 flashes/s with adjustable speed
- Color macros selectable by DMX
- Single pixel control

CONTROL AND PROGRAMMING

- 5 DMX configurations available: 1/4/9/32/36 channels
- Protocol USITT DMX 512
- Built-in DMX wireless receiver by Wireless Solutions
- Master / Slave mode with cable
- Static color mode with strobe adjustment
- Automatic mode with 13 different programs selectable from the display with speed adjustment
- Color mode with 51 different pre-programmed color macros
- IR remote controller included with possibility to select colors or macros (Included)
- Work power function for energy saving (eco mode)

STRUCTURE AND CABINET

- Die cast aluminium housing, black color
- Blue LCD graphic display
- Front tempered glass
- "Light up" positioning with angle adjustment
- DMX 3-poles XLR IP65 in/out connection
- IP rating: IP 65
- Convection cooling system without fans

POWER SUPPLY

- Input Voltage: AC~100-240V, 50/60 Hz, for normal working and battery recharge
- Switching power supply unit
- Internal rechargeable battery: 12VDC
- Capacity: 2x12 Ah
- Runtime battery: ~ 5 h (full ON)
- Max power: 80W @ 230VAC
- Charging cycle: ~ 8 h (Projector off)
- IP65 Powercon True ONE input power connection

WEIGHT AND DIMENSIONS

- Net weight: 9.3 kg
- Dimensions: 635x172x210 mm

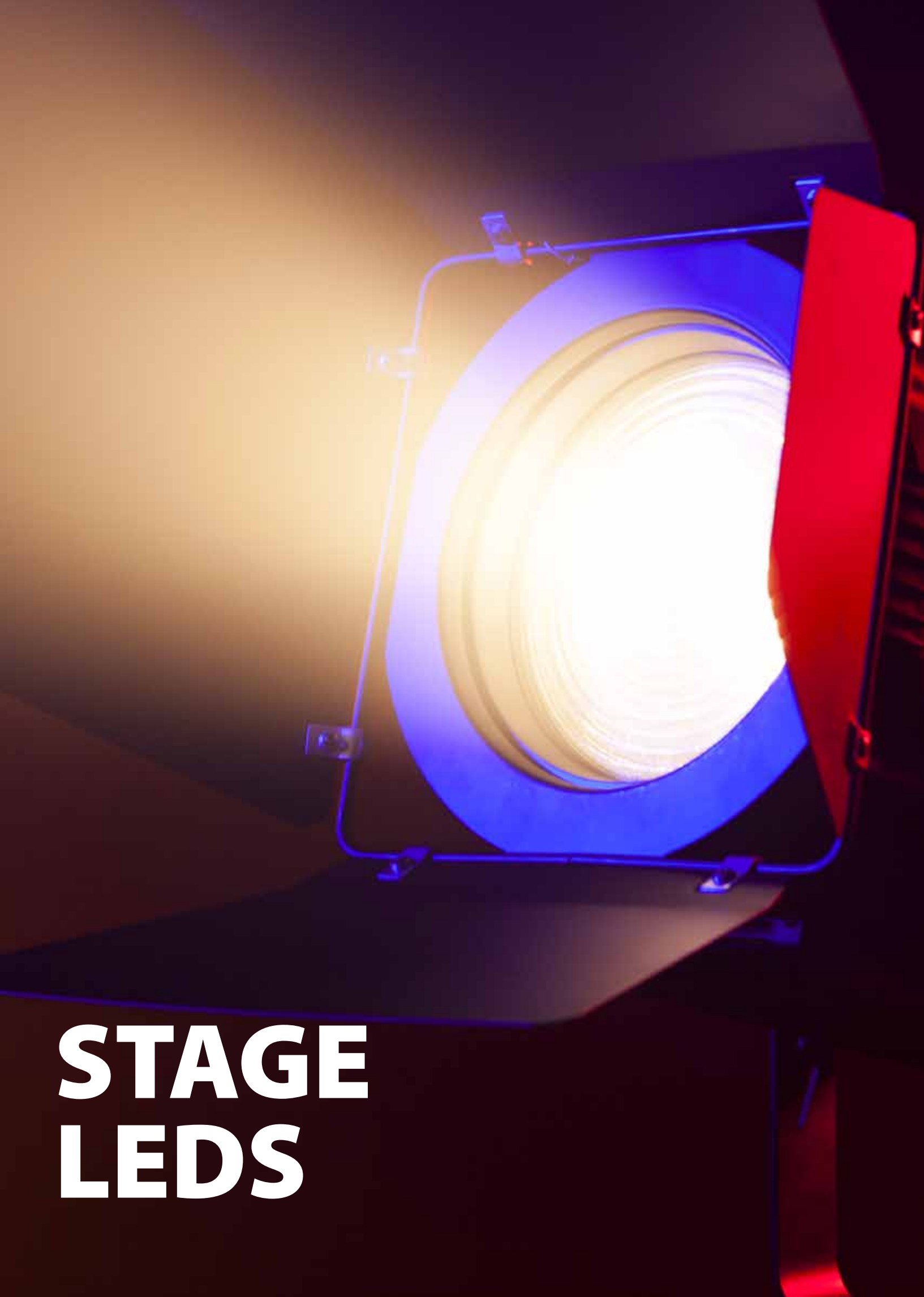

STAGE LEDS

SAGOLED 300



SG SAGOLEDWW300 - PRODUCT CODE WARM WHITE VERSION
SG SAGOLEDWCW300 - PRODUCT CODE COLD WHITE VERSION
SG CASESAGOLED300 - CASE (4x SG SAGOLED300)

LIGHT SOURCE

- 1x300W Led Warm White 3200K
- CRI \90Ra
- LED lifespan: >50,000h
- LED refresh frequency: >400Hz flicker free

OPTIC SYSTEM

- Beam angle: 26° (included)
- Optional: 19° - 36° - 50°
- Luminous flux: 6150 lux @5mt (19°)

COLOR SYSTEM

- Warm White 3200K COB LED Source

EFFECTS

- Linear dimmer 0-100%
- Electronic strobe: 1-20 flashes/s with adjustable speed

CONTROL AND PROGRAMMING

- 2 DMX channels configuration: 1/2 channels
- Protocol USITT DMX 512

STRUCTURE AND CABINET

- High resistance black Alluminium housing
- Blue LED graphic display
- Mounting points: single bracket for suspension
- Gel filter frame included
- Gobo holder included
- Iris (sold separately)
- 3-poles XLR in/out connection
- IP rating: IP20
- Forced Air fan cooling system with electronic control " Low Noise"

POWER SUPPLY

- Input Voltage: AC~100-240V 50/60Hz
- Switching power supply unit
- Max power: 350W @ 230VAC
- Power supply cable included

WEIGHT AND DIMENSIONS

- Net weight: 10,5kg
- Dimensions: 690x360x465 mm

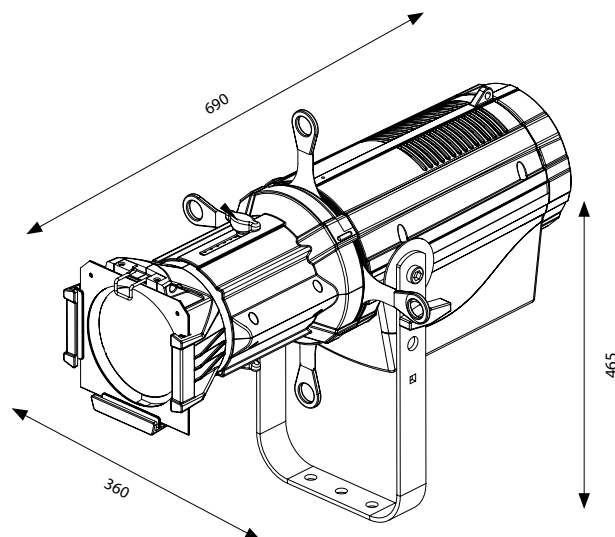

SAGOLED 230



NEW



SG SAGOLEDWW230 - PRODUCT CODE WARM WHITE VERSION
SG SAGOLEDWCW230 - PRODUCT CODE COLD WHITE VERSION
SG CASESAGOLED300 - CASE (4X SG SAGOLED230)

LIGHT SOURCE

- 1x230W Led Warm White 3200K
- CRI \90Ra
- LED lifespan: >50.000h
- LED refresh frequency: >400Hz flicker free

OPTIC SYSTEM

- Beam angle: 26° (included)
- Optional: 19° - 36° - 50°
- Luminous flux: 5050 lux @5mt (19°)

COLOR SYSTEM

- Warm White 3200K COB LED Source

EFFECTS

- Linear dimmer 0-100%
- Electronic strobe: 1-20 flashes/s with adjustable speed

CONTROL AND PROGRAMMING

- 2 DMX channels configuration: 1/2 channels
- Protocol USITT DMX 512

STRUCTURE AND CABINET

- High resistance black Aluminium housing
- Blue LED graphic display
- Mounting points: single bracket for suspension
- Gel filter frame included
- Gobo holder included
- Iris (sold separately)
- 3-poles XLR in/out connection
- IP rating: IP20
- Forced Air fan cooling system with electronic control "Low Noise"

POWER SUPPLY

- Input Voltage: AC~100-240V 50/60Hz
- Switching power supply unit
- Max power: 260W @ 230VAC
- Power supply cable included
- Power out max 4pcs @ 240VAC

WEIGHT AND DIMENSIONS

- Net weight: 10,5kg
- Dimensions: 690x360x465 mm

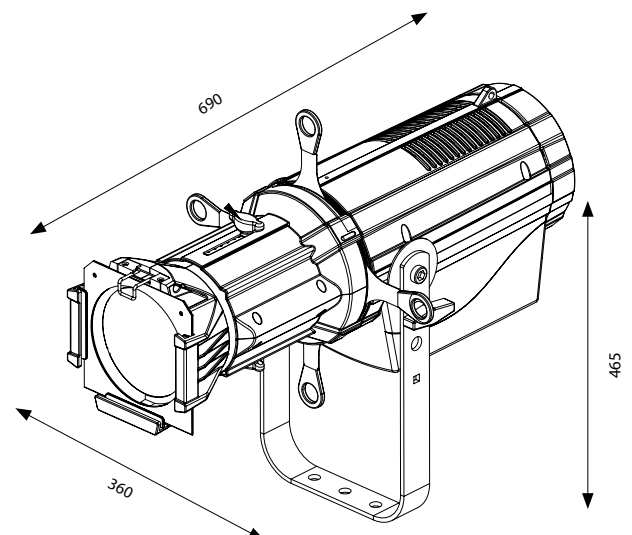

SAGOLED 120



SG SAGOLEDWW - PRODUCT CODE WARM WHITE VERSION
SG SAGOLEDW - PRODUCT CODE COLD WHITE VERSION
SG CASESAGOLED - CASE (4x SG SAGOLEDWW)

LIGHT SOURCE

- 1x120W Led Warm white 3200K
- LED lifespan: >50.000h
- LED refresh frequency: >400Hz flicker free

OPTIC SYSTEM

- Beam angle: 19° (included)
- Optional: 26° - 36° - 50°
- Luminous flux: 2950 lux @5mt (19°)

COLOR SYSTEM

- Warm White 3200K LED Source

EFFECTS

- Linear dimmer 0-100%
- Electronic strobe: 1-20 flashes/s with adjustable speed

CONTROL AND PROGRAMMING

- 1 DMX channels configuration: 2 channels
- Protocol USITT DMX 512
- Master / Slave mode
- Auto mode: 2 programs can be selected from display

STRUCTURE AND CABINET

- High resistance black plastic housing
- Red LED graphic display
- Mounting points: single bracket for suspension
- Gel filter frame included
- Gobo holder included
- Iris (sold separately)
- 3-poles XLR in/out connection
- IP rating: IP20
- Forced Air fan cooling system with electronic control

POWER SUPPLY

- Input Voltage: AC~100-240V 50/60Hz
- Switching power supply unit
- Max power: 150W @ 230VAC
- Power supply cable 1,5 mt

WEIGHT AND DIMENSIONS

- Net weight: 4,8 kg
- Dimensions: 643x360x465 mm

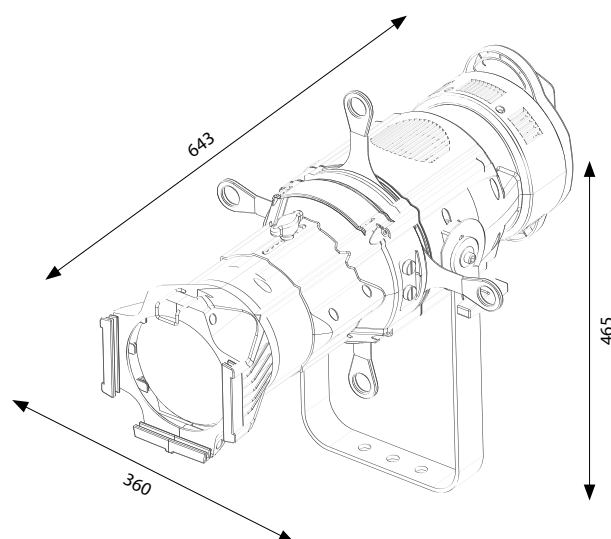

MINI SAGOLED 60



SG SAGOLEDWWM - PRODUCT CODE WARM WHITE VERSION
SG SAGOLEDWWM - PRODUCT CODE COLD WHITE VERSION
SG CASESAGOLEDM - CASE (4x SG SAGOLEDWWM)

LIGHT SOURCE

- 1x60W Led Warm white 3200K
- LED lifespan: > 50.000h
- LED refresh frequency: > 400Hz flicker-free

OPTIC SYSTEM

- Beam Angle: 19° (included)
- Optional: 26° - 36° - 50°

COLOR SYSTEM

- Warm White 3200K LED Source

EFFECTS

- Linear dimmer 0-100%
- Strobe: electronic 1-20 flashes/s with adjustable speed

CONTROL AND PROGRAMMING

- 1 DMX configurations available: 2 channels
- Protocol USITT DMX 512
- Master/Slave mode
- Auto mode: 2 programs can be selected from display

STRUCTURE AND CABINET

- High resistance black plastic housing
- Red LED display
- Mounting points: single bracket
- Gel filter frame included
- Gobo holder included
- Iris not included (sold separately)
- XLR 3-poles DMX IN/OUT connection with external USB box
- IP rating: IP20
- Controlled forced air fan cooling system "low noise"

POWER SUPPLY

- Input Voltage: AC~100-240V, 50/60 Hz
- Switching power supply unit
- Max power: 70W @ 230VAC
- IN/OUT power connection
- Power supply cable 1mt included
- Max 4 pcs linkable @ 240VAC

WEIGHT AND DIMENSIONS

- Net weight: 2,2 kg
- Dimensions: 158x305x238 mm

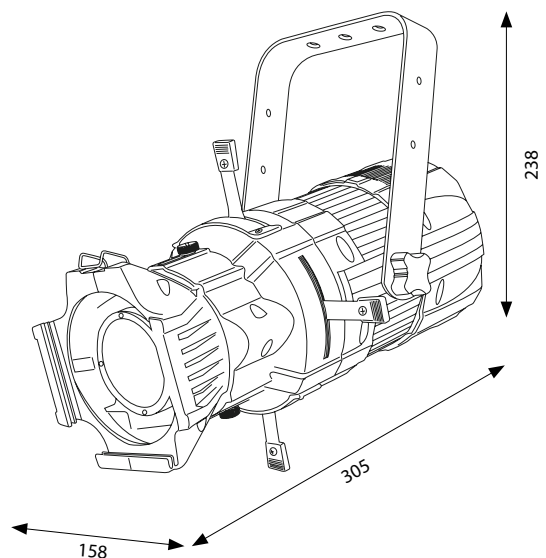

JUNIOR PROFILE



NEW



SG JNRPROWW - PRODUCT CODE WARM WHITE VERSION
SG JNRPROCW - PRODUCT CODE COLD WHITE VERSION
SG JNRPRORGBW - PRODUCT CODE RGBW VERSION
SG CASEJNRPRO - CASE (6X SG JNRPROWW)

LIGHT SOURCE

- 1x30W Led Warm white 3200K
- LED lifespan: > 50.000h
- LED refresh frequency: > 400Hz anti-flicker

OPTIC SYSTEM

- Beam Angle: 19° (included)
- Optional: 14° - 26° - 36°
- Luminous flux: 215 lux @5m (full on)

COLOR SYSTEM

- LED source Warm white 3200K

EFFECTS

- Linear dimmer 0-100%
- Strobe: electronic 1-20 flashes/s with adjustable speed

CONTROL AND PROGRAMMING

- 1 DMX channels configuration: 2 channels
- Protocol USITT DMX 512
- Auto mode: 1 programs can be selected from dip switch

STRUCTURE AND CABINET

- High resistance black plastic and aluminium housing
- Mounting points: single bracket
- Gel filter frame included
- Gobo holder included
- Iris not included (sold separately)
- XLR 3-poles DMX IN/OUT connection
- IP rating: IP20

POWER SUPPLY

- Input Voltage: AC~100-240V, 50/60 Hz
- Max power: 35W @ 230VAC
- Power supply cable 1mt included

WEIGHT AND DIMENSIONS

- Net weight: 1,1 kg
- Dimensions: 160x265x205 mm

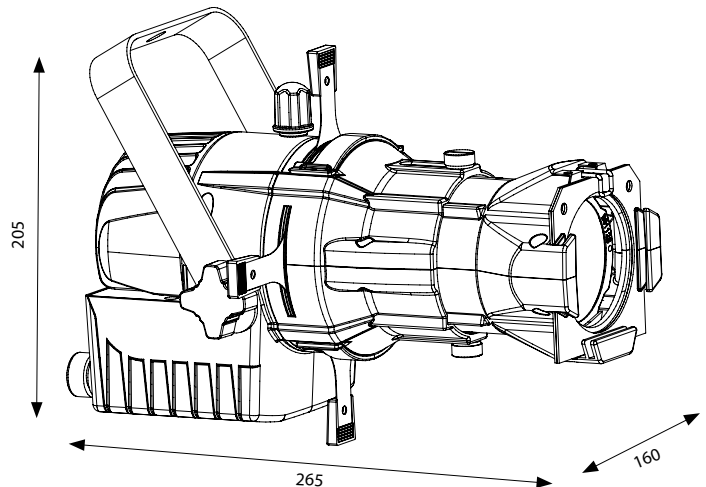



HALO FRESNEL LED 200



SG HALOFWW - PRODUCT CODE WARM WHITE VERSION
SG HALOFCW - PRODUCT CODE COLD WHITE VERSION
SG CASEHALOFR - CASE (4x SG HALOFWW)

LIGHT SOURCE

- 1X200W led COB Warm White 3200K
- CRI ≥85Ra
- LED lifespan: >50.000h
- LED refresh frequency: >400Hz flicker-free

OPTIC SYSTEM

- Beam angle: zoom from 15° to 55°
- Luminous flux: 2500 lux @5mt (15°)
- Luminous flux: 1390 lux @5mt (55°)

COLOR SYSTEM

- Warm White 3200K COB LED Source

EFFECTS

- Linear dimmer 0-100%
- Strobe: electronic 1-20 flashes/s with adjustable speed

CONTROL AND PROGRAMMING

- 2 different DMX channels configurations: 2/3 channels
- Protocol USITT DMX 512
- Manual mode for dimmer and zoom adjustment
- Direct manual control for zoom on the rear panel

STRUCTURE AND CABINET

- Black aluminum housing
- LCD blue graphic display
- Mounting points: single bracket for suspension
- Rotating barn door with "safety cable" (included)
- Single handle in the rear side for easy transportation
- 3/5-poles XLR in/out connection
- IP rating: IP 20
- Forced air cooling system "low noise" with fans for high efficiency and very low noise

POWER SUPPLY

- Input Voltage: AC~100-240V 50/60Hz
- Switching power supply unit
- Max power: 250W @ 230VAC
- IN / OUT power connection with powercon sockets
- Power supply cable 1,5 mt included
- Max 4 pcs linkable @ 240VAC

WEIGHT AND DIMENSIONS

- Net Weight: 8,4 kg
- Dimensions: 260x450x310 mm

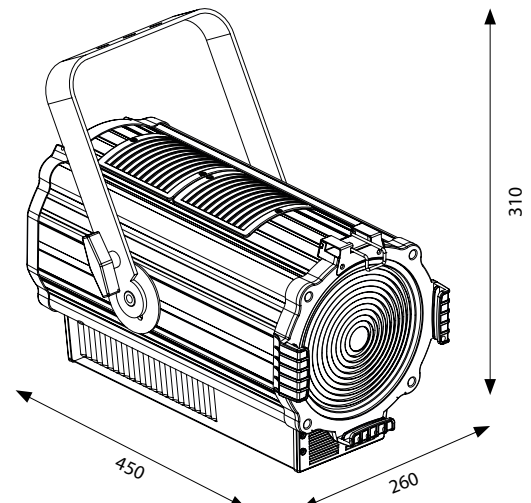

HALO FRESNEL LED 100



SG HALOFWWM - PRODUCT CODE WARM WHITE VERSION
SG HALOFCWM - PRODUCT CODE COLD WHITE VERSION
SG CASEHALOFR - CASE (4x SG HALOFWWM)

LIGHT SOURCE

- 1x100W Led COB Warm white 3200K
- CRI ≥ 85Ra
- LED lifespan: > 50.000h
- LED refresh frequency: > 400Hz flicker-free

OPTIC SYSTEM

- Beam Angle: manual zoom from 15° to 55°
- Luminous flux: 1683lux @ 5mt (15°)
- Luminous flux: 886lux @ 5mt (55°)

COLOR SYSTEM

- Warm White 3200K COB LED Source

EFFECTS

- Linear dimmer 0-100%
- Strobe: electronic 1-20 flashes/s with adjustable speed

CONTROL AND PROGRAMMING

- 2 DMX configurations available: 1/2 channels
- Protocol USITT DMX 512
- Manual dimmer mode

STRUCTURE AND CABINET

- Aluminium housing black color
- LCD blue graphic display
- Mounting points: single bracket
- Rotating barndoor with "safety cable" included
- XLR 3/5-poles DMX IN/OUT connection
- IP rating: IP20
- Controlled forced air fan cooling system "low noise"

POWER SUPPLY

- Input Voltage: AC~100-240V, 50/60 Hz
- Switching power supply unit
- Max power: 150W @ 230VAC
- IN/OUT power connection with PowerCON sockets
- Power supply cable 1mt included
- Max 8 pcs linkable @ 240VAC

WEIGHT AND DIMENSIONS

- Net weight: 7 kg
- Dimensions: 260x330x310 mm (without barndoor)

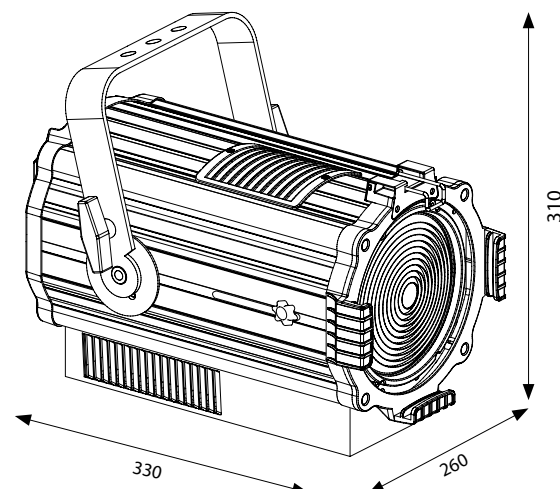



HALO FRESNEL LED 60



SG HALOFWWM60 - PRODUCT CODE WARM WHITE VERSION
SG HALOFCWM60 - PRODUCT CODE COLD WHITE VERSION
SG CASEHALOFM - CASE (4X SG HALOFWWM60)

LIGHT SOURCE

- 1x60W Led COB Warm white 3200K
- CRI ≥ 85Ra
- LED lifespan: > 50.000h
- LED refresh frequency: > 400Hz flicker-free

OPTIC SYSTEM

- Beam Angle: manual zoom from 15° to 55°
- Luminous flux: 1490lux @ 5mt (15°)
- Luminous flux: 530lux @ 5mt (55°)

COLOR SYSTEM

- Warm White 3200K LED Source

EFFECTS

- Linear dimmer 0-100%
- Strobe: electronic 1-20 flashes/s with adjustable speed

CONTROL AND PROGRAMMING

- 1 DMX configurations available: 2 channels
- Protocol USITT DMX 512
- Manual dimmer mode

STRUCTURE AND CABINET

- High resistance plastic housing
- Red LED display
- Mounting points: single bracket
- Rotating barn door with "safety cable" included
- XLR 3-poles DMX IN/OUT connection
- IP rating: IP20
- Controlled forced air fan cooling system "low noise"

POWER SUPPLY

- Input Voltage: AC~100-240V, 50/60 Hz
- Switching power supply unit
- Max power: 70W @ 230VAC
- IN/OUT power connection with PowerCON sockets
- Power supply cable 1mt included
- Max 4 pcs linkable @ 240VAC

WEIGHT AND DIMENSIONS

- Net weight: 2 kg
- Dimensions: 165x260x230 mm (without barn door)

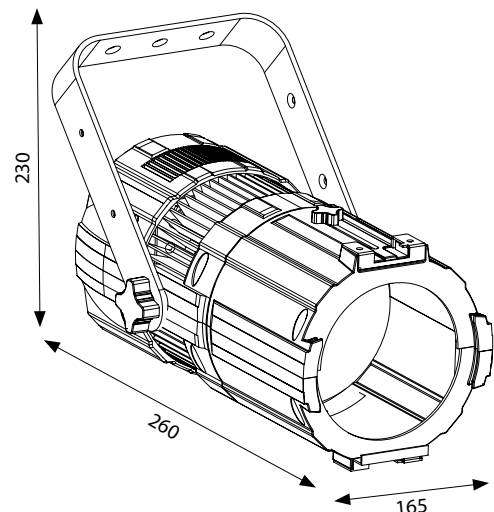

HALO PROFILE LED ZOOM 200 15-28



SG HALOPWW1528 - PRODUCT CODE WARM WHITE VERSION
SG HALOPCW1528 - PRODUCT CODE COLD WHITE VERSION
SG CASEHALOPR - CASE (4X SG HALOPWW1528)

LIGHT SOURCE

- 1X200W led COB Warm White 3200K
- CRI ≥85Ra
- LED lifespan: >50.000h
- LED refresh frequency: >400Hz flicker-free

OPTIC SYSTEM

- Beam angle: zoom from 15° to 28°
- Luminous flux: 4090lux @5mt (15°)
- Luminous flux: 1800lux @5mt (28°)

COLOR SYSTEM

- Warm White 3200K COB LED Source

EFFECTS

- Linear dimmer 0-100%
- Strobe: electronic 1-20 flashes/s with adjustable speed

CONTROL AND PROGRAMMING

- 2 different DMX channels configurations: 1/2 channels
- Protocol USITT DMX 512

STRUCTURE AND CABINET

- Black aluminum housing
- LCD blue graphic display
- Mounting points: single bracket for suspension
- Single handle in the rear side for easy transportation
- Gel filter frame included
- Gobo holder included
- Iris (sold separately)
- 3/5-poles XLR in/out connection
- IP rating: IP 20
- Forced air cooling system "low noise" with fans for high efficiency and very low noise

POWER SUPPLY

- Input Voltage: AC~100-240V 50/60Hz
- Switching power supply unit
- Max power: 250W @ 230VAC
- IN / OUT power connection with powercon sockets
- Power supply cable 1,5 mt included
- Max 4 pcs linkable @ 240VAC

WEIGHT AND DIMENSIONS

- Net Weight: 10kg
- Dimensions: 275x745x410 mm

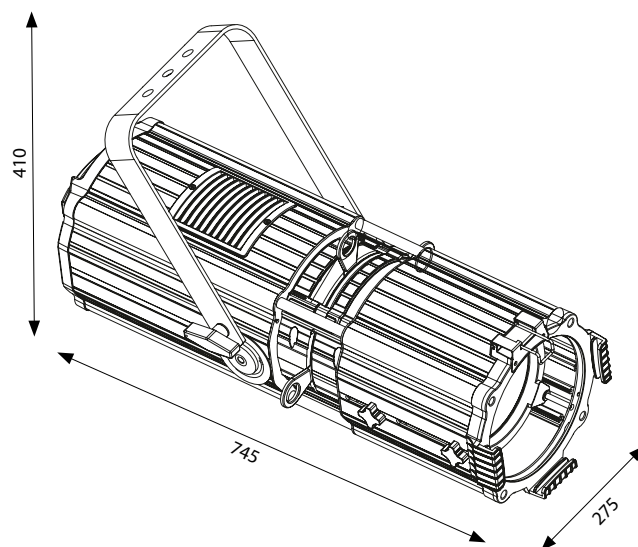



HALO PROFILE LED ZOOM 200 20-45

SG HALOPWW2045 - PRODUCT CODE WARM WHITE VERSION
SG HALOPCW2045 - PRODUCT CODE COLD WHITE VERSION
SG CASEHALOPR - CASE (4X SG HALOPWW2045)



LIGHT SOURCE

- 1X200W LED COB Warm White 3200K
- CR \geq 85Ra
- LED lifespan > 50.000h
- LED refresh frequency: > 400Hz flicker free

OPTIC SYSTEM

- Beam angle: zoom from 20° to 45°
- Luminous flux: 2950lux@5mt (20°)
- Luminous flux: 1550lux@5mt (45°)

COLOR SYSTEM

- Warm White 3200K COB LED Source

EFFECTS

- Linear dimmer 0 - 100%
- Strobe: electronic 1-20 flashes/s with adjustable speed

CONTROL AND PROGRAMMING

- 2 different DMX channels configurations: 1/2 channels
- Protocol USITT DMX 512

STRUCTURE AND CABINET

- Black aluminium housing
- LCD blue graphic display
- Fixing system with adjustable bracket
- Single handle in the rear side of the projector for easy transportation
- Gel filter frame included
- Gobo holder included
- Iris (sold separately)
- DMX control signal input and output XLR 3 poles
- IP rating: IP 20
- "low noise" controlled forced ventilation cooling system

POWER SUPPLY

- Input voltage: AC~100-240V 50/60Hz
- Switching power supply unit
- Max power: 250W @ 230VAC
- IN/OUT power connection with powercon sockets
- Power supply cable 1,5 mt included
- Max 4 pcs linkable @ 240VAC

WEIGHT AND DIMENSIONS

- Net Weight: 10kg
- Dimension: 275x645x410 mm

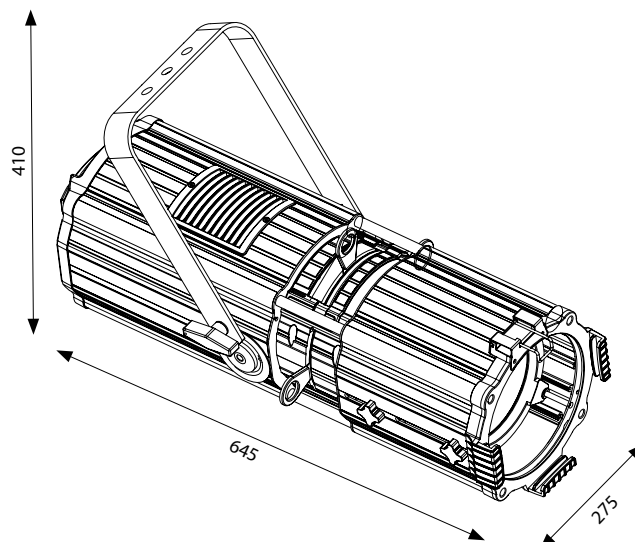

HALO PROFILE LED ZOOM 60



SG HALOPWWM60 - PRODUCT CODE WARM WHITE VERSION
SG HALOPCWM60 - PRODUCT CODE COLD WHITE VERSION
SG CASEHALOPM - CASE (4X SG HALOPWWM60)

LIGHT SOURCE

- 1X60W LED COB Warm White 3200K
- CRI≥85Ra
- LED lifespan > 50,000h
- LED refresh frequency: > 400Hz anti-flicker

OPTIC SYSTEM

- Beam angle: zoom from 19° to 36°
- Luminous flux: 890lux@5mt (19°)
- Luminous flux: 280lux@5mt (36°)

COLOR SYSTEM

- LED source COB warm white 3200K

EFFECTS

- Linear dimmer 0 - 100%
- Strobe: electronic 1-20 flashes/s with adjustable speed

CONTROL AND PROGRAMMING

- 1 different DMX channels configuration: 2 channels
- Protocol USITT DMX 512

STRUCTURE AND CABINET

- Black aluminium/plastic housing
- Fixing system with adjustable bracket
- External box for address, function settings and manual control of Dimmer
- DMX control signal input and output XLR 3 poles on the external box
- IP rating: IP 20
- "low noise" controlled forced ventilation cooling system

POWER SUPPLY

- Input voltage: AC~100-240V 50/60Hz
- Switching power supply unit
- Max power: 65W @ 230VAC
- IN/OUT power connection
- Power supply cable 1 mt included
- Max 4 pcs linkable @ 240VAC

WEIGHT AND DIMENSIONS

- Net Weight: 3.5 kg
- Dimension: 180x440x300 mm

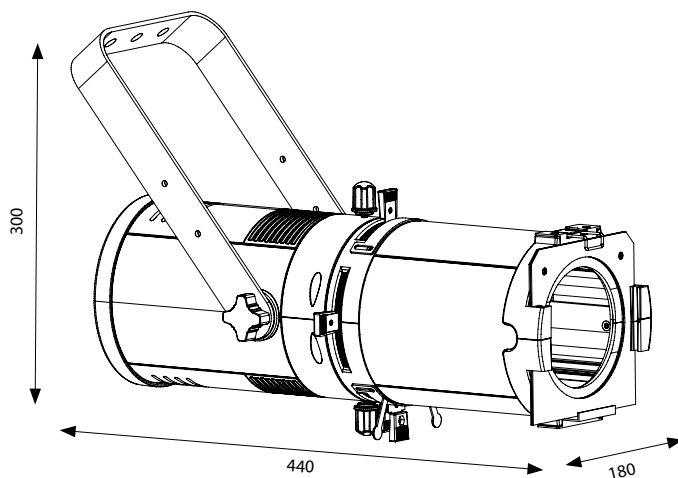



STUDIO LED PANEL RGB



SG STUDIOPRGB - PRODUCT CODE
SG CASESTUDIOP - CASE (4x SG STUDIOP)

LIGHT SOURCE

- 1456 RGB leds
- LED lifespan: >50.000h
- LED refresh frequency: >400Hz flicker-free

OPTIC SYSTEM

- Beam angle: 110°

COLOR SYSTEM

- RGB led color mixing

EFFECTS

- Linear Dimmer 0-100%
- Adjustable Strobe

CONTROL AND PROGRAMMING

- 1 DMX configuration available: 6 channels
- Protocol USITT DMX 512
- Master/Slave mode

STRUCTURE AND CABINET

- Die cast aluminum housing
- Blue LCD graphic display
- 3/5 poles XLR in/out dmx signal connections
- Convection cooling system without fans
- Barn door included

POWER SUPPLY

- Input Voltage: AC~100-240V, 50/60 Hz
- Switching power supply unit
- Max power: 250W @ 230VAC
- Power supply cable included

WEIGHT AND DIMENSIONS

- Net weight: 11,5 kg
- Dimensions: 490x150x275 mm

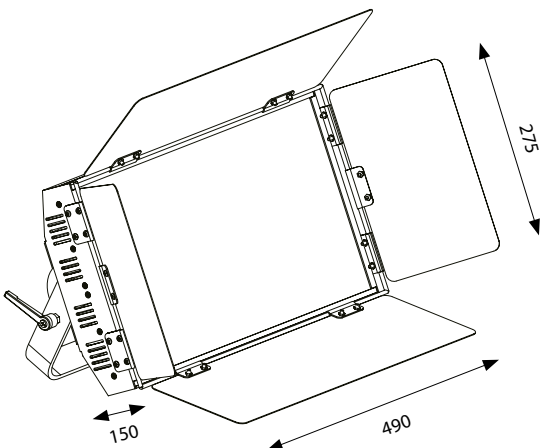

STUDIO LED PANEL WHITE

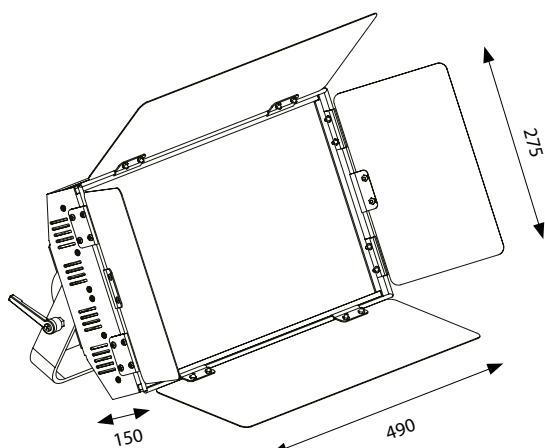

SG STUDIOPWW - PRODUCT CODE WARM WHITE VERSION
SG STUDIOPCW - PRODUCT CODE COLD WHITE VERSION
SG CASESTUDIOP - CASE (4x SG STUDIOP)

LIGHT SOURCE

- 1456 Warm White 3200K leds
- CRI \geq 90 Ra
- LED lifespan: >50,000h
- LED refresh frequency: >400Hz flicker-free

OPTIC SYSTEM

- Beam angle: 110°

EFFECTS

- Linear Dimmer 0-100%
- Adjustable Strobe

CONTROL AND PROGRAMMING

- 2 DMX configuration available: 1/2 channels
- Protocol USITT DMX 512
- Master/Slave mode

STRUCTURE AND CABINET

- Die cast aluminum housing
- Blue LCD graphic display
- 3/5 poles XLR in/out dmx signal connections
- Convection cooling system without fans
- Barndoor included

POWER SUPPLY

- Input Voltage: AC~100-240V, 50/60 Hz
- Switching power supply unit
- Max power: 250W @ 230VAC
- Power supply cable included

WEIGHT AND DIMENSIONS

- Net weight: 11,5 kg
- Dimensions: 490x150x275 mm

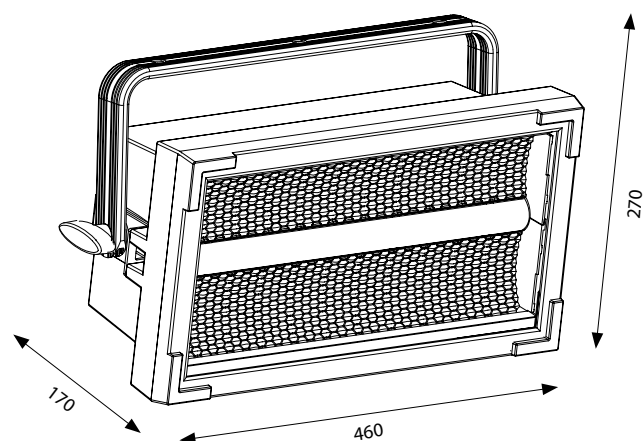

SG BLAZER1500C - PRODUCT CODE
SG CASEBLAZERC - CASE (4X SG BLAZER1500C)

LIGHT SOURCE

- 228 White led 6500K + 64 RGB led
- LED lifespan: > 50.000h
- LED refresh frequency: > 400Hz flicker-free

OPTIC SYSTEM

- Beam Angle: 90x140°

EFFECTS

- Linear dimmer 0-100%
- Adjustable strobe effect
- Random strobe effect
- Sectors control
- RGB Aura effect

CONTROL AND PROGRAMMING

- Dynamic Patterns with direction and speed control
- RGB Aura effect Effects with 36 pre-programmed color macros
- RGB Aura Color rainbow and automatic color change
- 4 DMX configurations available: 3/4/14/18 channels
- Protocol USITT DMX 512

STRUCTURE AND CABINET

- High resistance black plastic housing
- Graphic LCD display
- Mounting points: single adjustable bracket
- XLR 3-poles DMX IN/OUT connections
- Controlled forced air fan cooling system

POWER SUPPLY

- Input Voltage: AC~100-240V, 50/60 Hz
- Switching power supply unit
- Max power: 2000W @ 230VAC
- Power supply cable included

WEIGHT AND DIMENSIONS

- Net weight: 6,5 kg
- Dimensions: 460x170x270 mm

STAGE LEDS

BLOK 2TW



NEW



SG BLOK2TW - PRODUCT CODE
SG CASEBLOK2 - CASE (4X SG BLOK2TW)
SG BLOK2TWH - HARDWARE CONNECTION SYSTEM

LIGHT SOURCE

- 2x100W led COB Warm White 3200K
- CRI≥85Ra
- LED lifespan: > 50.000h
- LED refresh frequency: > 400Hz anti-flicker

OPTIC SYSTEM

- Beam Angle: 94°

COLOR SYSTEM

- LED COB Warm White 3200K

EFFECTS

- Linear dimmer 0-100%
- Adjustable strobe effect
- RED-Shift effect for Halogen blinder simulation
- Single eye control

CONTROL AND PROGRAMMING

- 6 DMX configurations available: 1/4/6/2/6/10 channels
- Key lock password for display lock
- Protocol USITT DMX 512

STRUCTURE AND CABINET

- Die cast aluminium housing
- Hardware system connection for multiple projectors stack (SG BLOK2TWH sold separately)
- LCD graphic display
- "Light up" positioning with adjustable angle
- IP rating: IP65
- DMX 3-poles XLR IP65 IN/OUT connectors
- Low Noise controlled forced ventilation cooling system

POWER SUPPLY

- Input Voltage: AC~100-240V, 50/60 Hz
- Switching power supply unit
- Max Power: 315W @ 230VAC
- IP65 Powercon True ONE IN/OUT connectors

WEIGHT AND DIMENSIONS:

- Net weight: 8,2 kg
- Dimensions: 400x240x230 mm

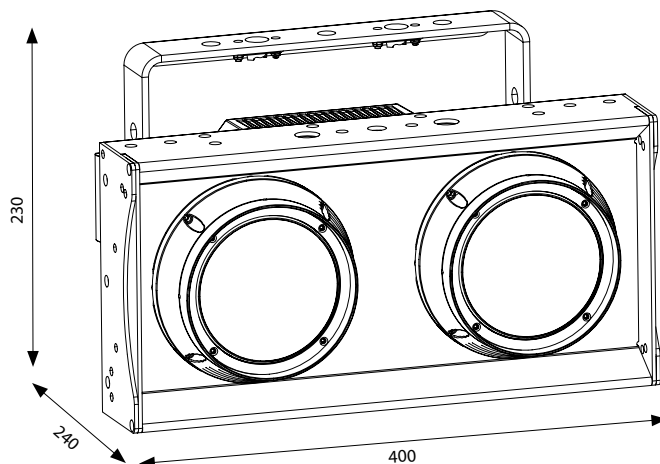

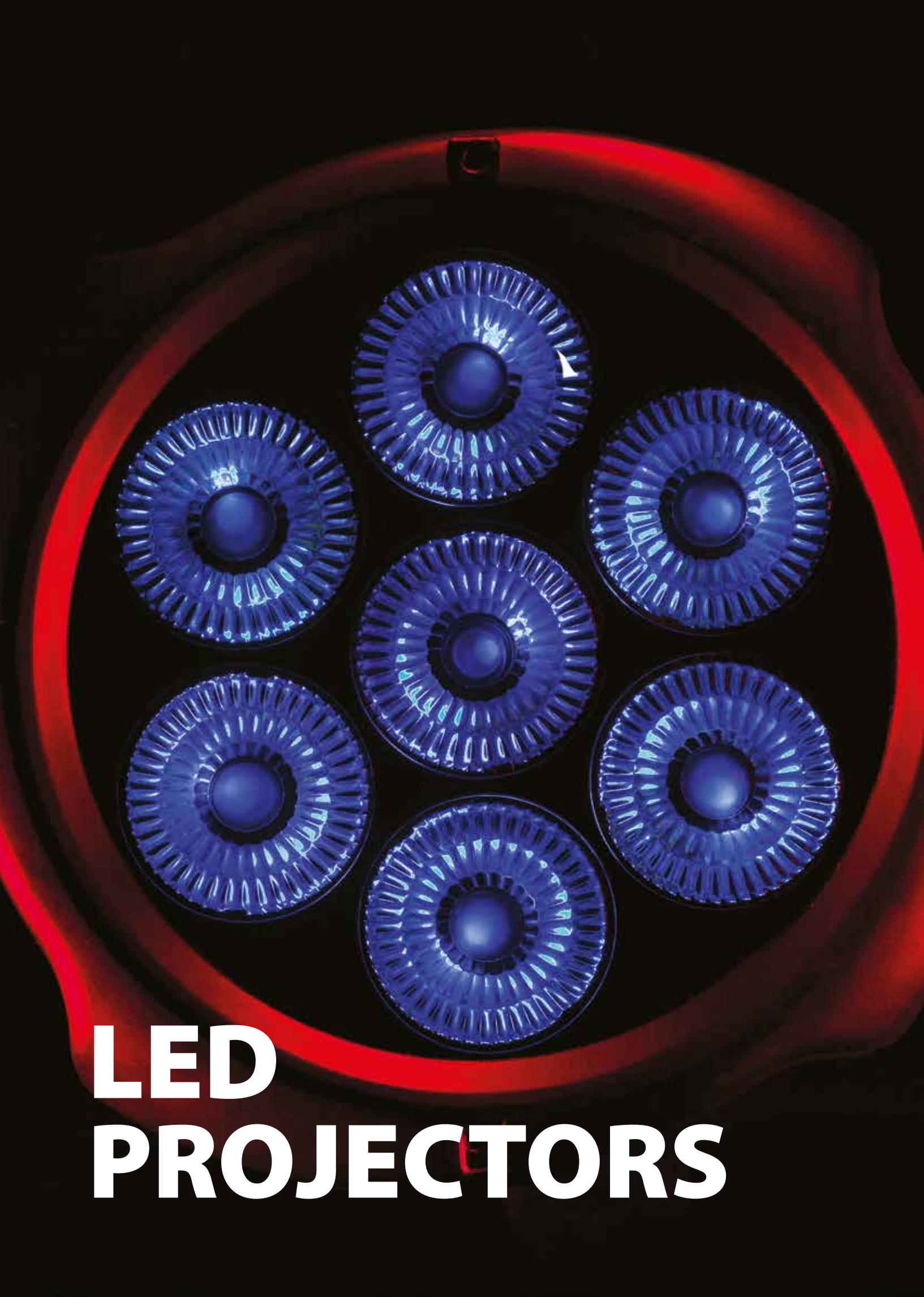

LED PROJECTORS

LED PROJECTORS

AQUPAR 7



SG AQUPAR7 - PRODUCT CODE SG CASEAQUPAR - CASE (6x SG AQUPAR)

LIGHT SOURCE

- 7x12W RGBWA-UV led
- LED lifespan: >50,000h
- LED refresh frequency: >400Hz flicker free

OPTIC SYSTEM

- Beam angle: 25°

COLOR SYSTEM

- RGBWA-UV full color mixing
- Infinite chromatic possibilities and color temperature control

EFFECTS

- Linear Dimmer 0-100%
- Electronic strobe: 1-20 flashes/s with adjustable speed
- Color macros selectable via DMX

CONTROL AND PROGRAMMING

- 4 DMX configurations available: 3/6/8/13 channels
- Key lock password for display lock
- Master / Slave mode
- Automatic mode with 21 different programs selectable from the display with independent adjustment of the speed and strobe
- Color mode with independent adjustment of single color with 70 different selections
- 11 white balance selections
- 4 dimmer curves

STRUCTURE AND CABINET

- Die cast aluminum housing, black color
- Color LCD display
- Front tempered glass
- Mounting points: double bracket for suspension or floor support
- IP rating: IP65
- 3-poles XLR in/out DMX connection IP65
- Convection cooling system without fans

POWER SUPPLY

- Input Voltage: AC~100-240V, 50/60 Hz
- Switching power supply unit
- Max power: 85W @ 230VAC
- Power IN/OUT connection IP65

WEIGHT AND DIMENSIONS

- Net weight: 3,2 kg
- Dimensions: 250x175x230 mm

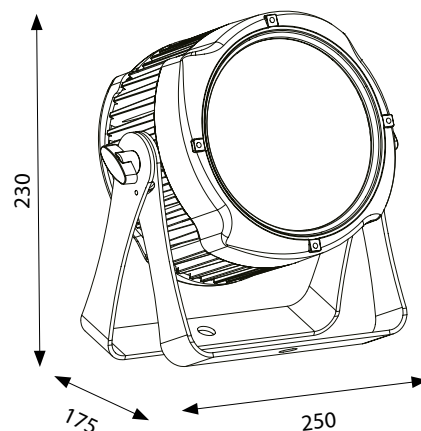



LED PROJECTORS

AQUPAR 12



SG AQUPAR12 - PRODUCT CODE
SG CASEAQUPAR - CASE (6x SG AQUPAR)
SG AQUPARBN - BARNDOOR

LIGHT SOURCE

- 12x12W RGBWA-UV led
- LED lifespan: >50.000h
- LED refresh frequency: >400Hz flicker free

OPTIC SYSTEM

- Beam angle: 25°

COLOR SYSTEM

- RGBWA-UV full color mixing
- Infinite chromatic possibilities and color temperature control

EFFECTS

- Linear Dimmer 0-100%
- Electronic strobe: 1-20 flashes/s with adjustable speed
- Color macros selectable via DMX

CONTROL AND PROGRAMMING

- 4 DMX configurations available: 3/6/8/13 channels
- Key lock password for display lock
- Master / Slave mode
- Automatic mode with 21 different programs selectable from the display with independent adjustment of the speed and strobe
- Color mode with independent adjustment of single color with 70 different selections
- 11 white balance selections
- 4 dimmer curves

STRUCTURE AND CABINET

- Die cast aluminum housing, black color
- Color LCD display
- Front tempered glass
- Mounting points: double bracket for suspension or floor support
- IP rating: IP65
- 3-poles XLR in/out DMX connection IP65
- Convection cooling system without fans

POWER SUPPLY

- Input Voltage: AC~100-240V, 50/60 Hz
- Switching power supply unit
- Max power: 145W @ 230VAC
- Power IN/OUT connection IP65

WEIGHT AND DIMENSIONS

- Net weight: 4,8 kg
- Dimensions: 300x215x290 mm

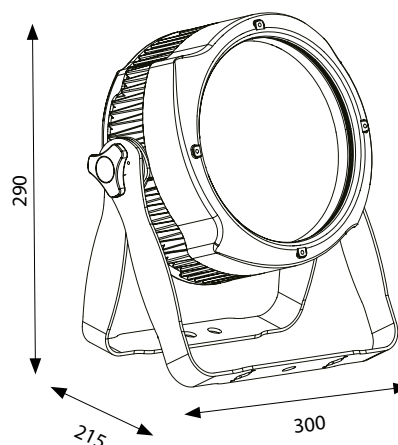

LED PROJECTORS

AQUPAR 18



SG AQUPAR18 - PRODUCT CODE
SG CASEAQUPAR - CASE (6x SG AQUPAR)
SG AQUPARBN - BARNDOOR

LIGHT SOURCE

- 18x10W RGBW led
- LED lifespan: >50.000h
- LED refresh frequency: >400Hz flicker free

OPTIC SYSTEM

- Beam angle: 25°

COLOR SYSTEM

- RGBW full color mixing
- Infinite chromatic possibilities and color temperature control

EFFECTS

- Linear Dimmer 0-100%
- Electronic strobe: 1-20 flashes/s with adjustable speed
- Color macros selectable via DMX

CONTROL AND PROGRAMMING

- 4 DMX configurations available: 3/4/6/11 channels
- Key lock password for display lock
- Master / Slave mode
- Automatic mode with 21 different programs selectable from the display with independent adjustment of the speed and strobe
- Color mode with independent adjustment of single color with 70 different selections
- 11 white balance selections
- 4 dimmer curves

STRUCTURE AND CABINET

- Die cast aluminum housing, black color
- Color LCD display
- Front tempered glass
- Mounting points: double bracket for suspension or floor support
- IP rating: IP65
- 3-poles XLR in/out DMX connection IP65
- Convection cooling system without fans

POWER SUPPLY

- Input Voltage: AC~100-240V, 50/60 Hz
- Switching power supply unit
- Max power: 185W @ 230VAC
- Power IN/OUT connection IP65

WEIGHT AND DIMENSIONS

- Net weight: 4,8 kg
- Dimensions: 300x215x290 mm

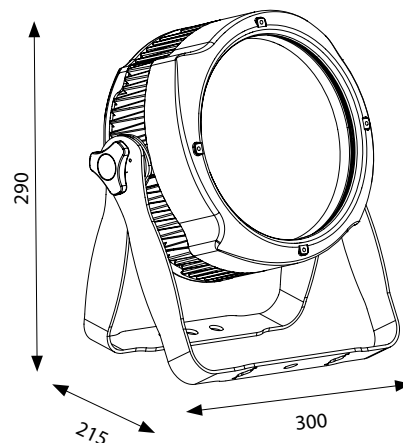



**COB
PROJECTORS**

COB PROJECTORS

SOLPAR C60Z



SG SOLPARC60Z - PRODUCT CODE
SG CASESOLPAR60 - CASE (6x SG SOLPARC60)
SG SOLPARC60BN - BARNDOOR

LIGHT SOURCE

- 1x60W RGBW COB led
- LED lifespan: >50.000h
- LED refresh frequency: >400Hz flicker-free

OPTIC SYSTEM

- Beam angle: motorized zoom from 15° to 40°

COLOR SYSTEM

- RGBW full color mixing
- Infinite chromatic possibilities

EFFECTS

- Linear dimmer 0-100%
- Adjustable strobe
- Color Macros selectable from DMX

CONTROL AND PROGRAMMING

- 4 DMX configuration available: 3/5/7/9 channels
- Key password for display settings lock
- Protocol USITT DMX 512
- Master/Slave mode
-
- Play/Edit User Mode with the possibility to run and edit 20 timed programs
- 5 dimmer curves

STRUCTURE AND CABINET

- Die cast aluminum housing
- Blue LCD graphic display
- Soft touch buttons
- Tempered front glass
- "light up" positioning without brackets
- IP65 protection grade
- IP65 3/5 poles XLR in/out dmx signal connections
- Convection cooling system without fans
- Optional barn door (code:SG SOLPARC60BN)

POWER SUPPLY

- Input Voltage: AC~100-240V, 50/60 Hz
- Switching power supply unit
- Max power: 78W @ 230VAC
- IP65 Powercon True ONE in/out power connections
- Power supply cable included

WEIGHT AND DIMENSIONS

- Net weight: 5,5 kg
- Dimensions: 280x300x280 mm

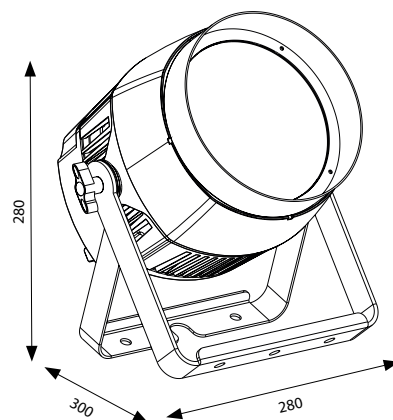

COB PROJECTORS

SOLPAR C150Z



SG SOLPARC150Z - PRODUCT CODE
SG CASESOLPAR150 - CASE (6x SG SOLPARC150)
SG SOLPARC150BN - BARNDOOR

LIGHT SOURCE

- 1x120W RGBW COB led
- LED lifespan: >50.000h
- LED refresh frequency: >400Hz flicker-free

OPTIC SYSTEM

- Beam angle: motorized zoom from 15° to 40°

COLOR SYSTEM

- RGBW full color mixing
- Infinite chromatic possibilities

EFFECTS

- Linear dimmer 0-100%
- Adjustable strobe
- Color Macros selectable from DMX

CONTROL AND PROGRAMMING

- 4 DMX configuration available: 3/5/7/9 channels
- Key password for display settings lock
- Protocol USITT DMX 512
- Master/Slave mode
- Macro mode with 63 built-in programs selectable from the display
- Play/Edit User Mode with the possibility to run and edit 20 timed programs
- 5 dimmer curves

STRUCTURE AND CABINET

- Die cast aluminum housing
- Blue LCD graphic display
- Soft touch buttons
- Tempered front glass
- "light up" positioning without brackets
- IP65 protection grade
- IP65 3/5 poles XLR in-out dmx signal connections
- Convection cooling system without fans
- Optional barndoor (code:SG SOLPARC150BN)

POWER SUPPLY

- Input Voltage: AC~100-240V, 50/60 Hz
- Switching power supply unit
- Max power: 135W @ 230VAC
- IP65 Powercon True ONE in/out power connections
- Power supply cable included

WEIGHT AND DIMENSIONS

- Net weight: 9,2 kg
- Dimensions: 355x330x330 mm

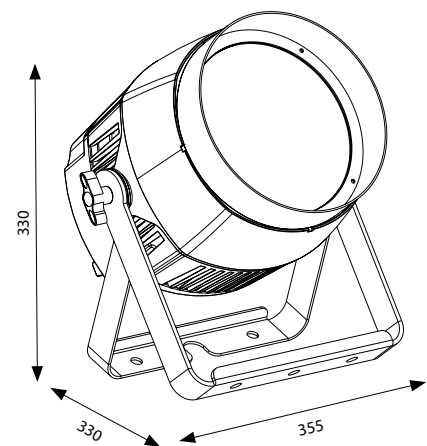



LED BATTERY PROJECTORS



LED BATTERY PROJECTORS

FLOORBAT Q3



SG FLBATQ3 - PRODUCT CODE
SG FLBATCBOX - CHARGER BOX

LIGHT SOURCE

- 3x12W led RGBWA - UV full color led
- LED lifespan: > 50.000h
- LED refresh frequency: > 400Hz flicker-free

OPTIC SYSTEM

- Beam Angle: 15°

COLOR SYSTEM

- RGBWA-UV full color mixing
- Infinite chromatic possibilities

EFFECTS

- Linear dimmer 0-100%
- Adjustable strobe effect
- Static color mode: manual adjustment for each color
- Manual color mode: static built-in color macros
- Auto mode: built-in automatic programs with adjustable speed
- Sound mode: sound activation with internal microphone with adjustable sensitivity
- 3 dimmer curves

CONTROL AND PROGRAMMING

- 3 DMX configurations available: 6/8/12 channels
- Protocol USITT DMX 512
- Built-in DMX wireless transceiver by Wireless Solutions
- Master/Slave mode
- Auto mode
- IR remote controller included with possibility to recall colors or macros

STRUCTURE AND CABINET

- Metal housing
- OLED display
- Touch button for selection
- "Light up" positioning with adjustable angle
- IP rating: IP20
- Convection cooling system without fans

POWER SUPPLY

- Power supply: 12,8Vdc, 1,4A
- Rechargeable internal Lithium battery
- Runtime battery: ~ 4 hrs (full ON)
- Max power: 36W

WEIGHT AND DIMENSIONS

- Net weight: 1,6 kg
- Dimensions: 145x145x65 mm

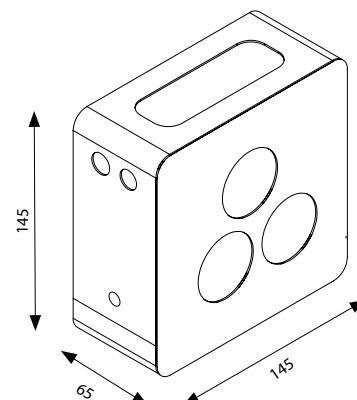

LED BATTERY PROJECTORS

FLOORBAT Q1



SG FLBATQ1 - PRODUCT CODE
SG FLBATCHBOX - CHARGER BOX

LIGHT SOURCE

- 1x15W RGBW full color led
- LED lifespan: > 50.000h
- LED refresh frequency: > 400Hz flicker-free

OPTIC SYSTEM

- Beam Angle: 15°

COLOR SYSTEM

- RGBW full color mixing
- Infinite chromatic possibilities

EFFECTS

- Linear dimmer 0-100%
- Adjustable strobe effect
- Static color mode: manual adjustment for each color
- Manual color mode: static built-in color macros
- Auto mode: built-in automatic programs with adjustable speed
- Sound mode: sound activation with internal microphone with adjustable sensitivity
- 3 dimmer curves

CONTROL AND PROGRAMMING

- 3 DMX configurations available: 4/6/11 channels
- Protocol USITT DMX 512
- Built-in DMX wireless transceiver by Wireless Solutions
- Master/Slave mode
- Auto mode
- IR remote controller included with possibility to recall colors or macros

STRUCTURE AND CABINET

- Metal housing
- OLED display
- Touch button for selection
- "Light up" positioning with adjustable angle
- IP rating: IP20
- Convection cooling system without fans

POWER SUPPLY

- Power supply: 12,8Vdc, 1,4A
- Rechargeable internal Lithium battery
- Runtime battery: ~ 5 hrs (full ON)
- Max power: 15W

WEIGHT AND DIMENSIONS

- Net weight: 1,6 kg
- Dimensions: 145x145x65 mm

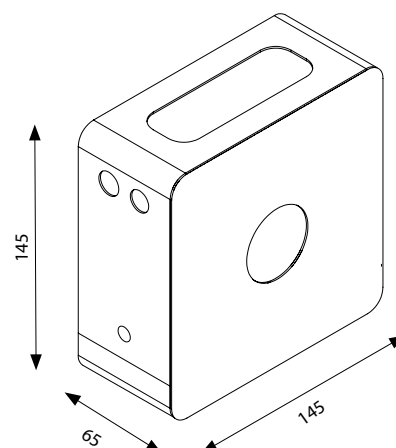



LED BATTERY PROJECTORS

AIR BOX

SG AIRBOX - PRODUCT CODE
SG AIRBOXIP - IP VERSION

TECHNICAL DATA

- DMX Wireless Transmitter/Receiver by Wireless Solution for FLOORBAT Serie
- Number of channels: 512
- Operational mode: Transmitter/Receiver
- Operational Frequency: 2.4 GHZ
- Up to 250m range working distance
- Interference free
- Protocol Standard: USITT Dmx 512/1990
- Data connection: dmx in/out through 3 poles connectors
- Modulation method: GFSK
- Adaptive Frequency Hopping
- Error correction

POWER SUPPLY

- Input voltage: 5 Vdc

WEIGHT AND DIMENSIONS

- Weight: 0,39 Kg
- Dimensions: 135x140x34 mm

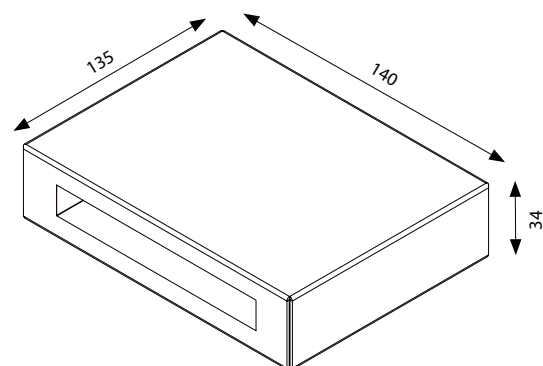



CONTROLLERS

CONTROLLERS

QUIVER



SG QUIVER - PRODUCT CODE

SG CASEQUIVER - CASE (1X SG QUIVER)

SG CASEQUIVER1X - CASE (1X SG QUIVER + 1X SG QUIVERX)

SG CASEQUIVER2X - CASE (1X SG QUIVER + 2X SG QUIVERX)

SG QUIVERWI - WIRELESS TRANSMITTER DMX WIDMX

SG QUIVERWIZ - WIRELESS TRANSMITTER DMX WSOLUTION

CONTROLS

- Colour Display touch-screen TFT LCD 7"
- 6 control keys for editor
- 6 configurable slider as playback, master group
- 6 configurable key as play, flash, DBO
- 12 keys for direct access to playback and CUES
- 4 touch-fader for the control of the attributes during the programming and control of the effects and during playback and manual use
- Joystick for PAN and TILT movement control with lock and fine/super fine keys

DESCRIPTION

- Effective graphic interface able to easily manage programming and playback for a maximum of 144 cue-list organize in 12 pages each having a maximum of 999 cues
- 512 channel for each single universe DMX for the control of dimmer and/or intelligent projector, available simultaneously on XLR connector 3 poles
- Up to 1536 channel with Quiver Expand
- Up to 36 Cue-list run concurrently (with 2 Expand connected)
- "Shape engine" customizable and applicable to different functions (PAN&TILT - DIM - COLOR - GOBO - BLADE)
- Up to 6 different families of "palettes" programmable for a flexible and easy control of intelligent projectors
- Up to 999 Cues for each playback
- Library "personalities" upgradeable, creating fixture via software for PC (included)
- "Palettes" Chris/Gam/Lee and Rosco pre-program usable on all machines with mixing colors RGB or CMY
- Maximum Number of storable cues to show: 999
- RDM ready (Prepared for enlargement of technology)
- Wireless ready (Designed for the insertion of a wireless transmitter sold separately)
- External Power Supply: 100-240V 50-60Hz
- USB Pendrive (included)
- USB Gooseneck led light (included)
- Protective cover (included)

CONNECTIONS

- DMX out: 1x XLR 3 poles
- Expand: 2x RJ45 for expansions connection
- USB 1x port for backup, lamp power supply and update the fixture
- Jack 6,3mm for connecting the pedals for controlling the gearbox scenes

WEIGHT AND DIMENSIONS:

- Net weight: 3,4 kg
- DIMENSIONS: 420X98X288 mm

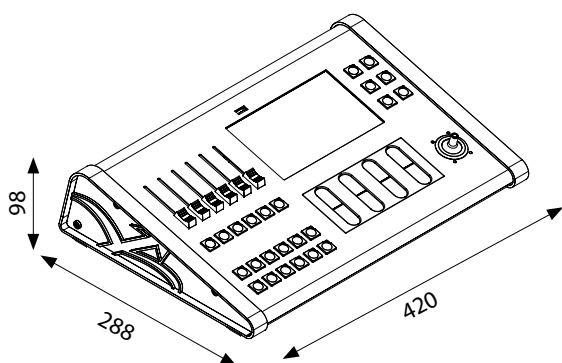

CONTROLLERS

QUIVER X



SG QUIVERX - PRODUCT CODE

CONTROLS

- 6 configurable slider as playback, master group
- 6 configurable key as play, flash, DBO
- 12 keys for direct access to playback and CUES

CONNECTIONS

- DMX out: 1x XLR 3 poles
- Expand: 1x RJ45 for expansions connection to Quiver

WEIGHT AND DIMENSIONS:

- Net weight: 1,4 kg
- Dimensions: 196x98x288 mm



EXAMPLE OF CASE



QUIVER + 1 QUIVER X



QUIVER + 2 QUIVER X

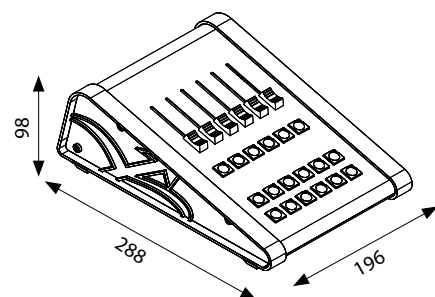

Hazer Heating
is Complete



OUT - ADMS APINT IN



AMBIENT EFFECTS

AMBIENT EFFECT

HAZER 1500

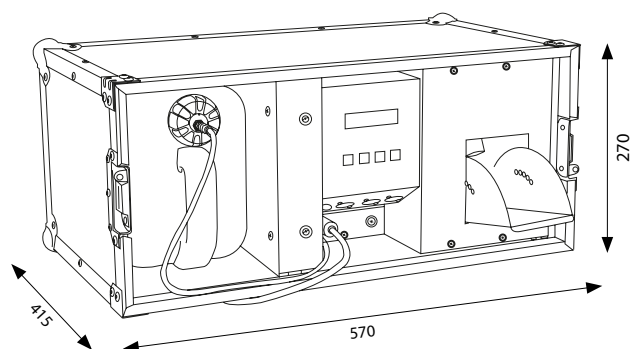

SG H1500 - PRODUCT CODE

EFFECTS

- Hazer effect

CONTROL AND PROGRAMMING

- 2 different DMX channels configurations
- Fan's speed adjustable via software and via DMX
- Protocol USITT DMX 512
- Automatic safety shutdown circuit for pump prevention in case of finished liquid in the circuit
- Heating time: 4 mins
- Smoke output: 1700cuft
- Continue output
- Manual mode adjustable via display

STRUCTURE AND CABINET

- Metal black housing
- LCD blue graphic display
- Flight case included, for easy transportation
- Comfortable handle for transportation
- High performance pump for optimal emission
- High speed axial fan
- External tank: 6 litres
- 3/5 poles XLR in/out connection
- IP rating: IP20
- For best applications and correct function we recommend using Sagitter fluids

POWER SUPPLY

- Input Voltage: AC~230V 50Hz
- Max power: 1500W @ 230VAC
- IN power connection with powerCON sockets
- Power supply cable 1,5 mt included

WEIGHT AND DIMENSIONS:

- Net weight: 18 kg
- Dimensions: 570x415x270 mm



AMBIENT EFFECT

HS - 900



NEW

SG HS900 - PRODUCT CODE

EFFECTS

- Hazer effect

CONTROL AND PROGRAMMING

- 1 DMX channel configuration: 2 channels
- Fan's speed adjustable via DMX
- Protocol USITT DMX 512
- Radio remote controller included
- Heating time: 2 mins
- Smoke output: 1300cuft
- Continue output
- Manual mode adjustable via display

STRUCTURE AND CABINET

- Metal black housing
- LCD blue graphic display
- Led indicator for heating and ready to smoke
- High performance pump for optimal emission
- High speed fan
- External tank: 3 litres
- 3-poles XLR in/out connection
- IP rating: IP20
- For best applications and correct function we recommend using Sagitter fluids

POWER SUPPLY

- Input Voltage: AC~230V, 50Hz
- Max Power: 650 W @ 230VAC
- IN power connection with VDE sockets
- Power supply cable 1,5 mt included

WEIGHT AND DIMENSIONS

- Net weight: 7,3 kg
- Dimensions: 357x335x323 mm

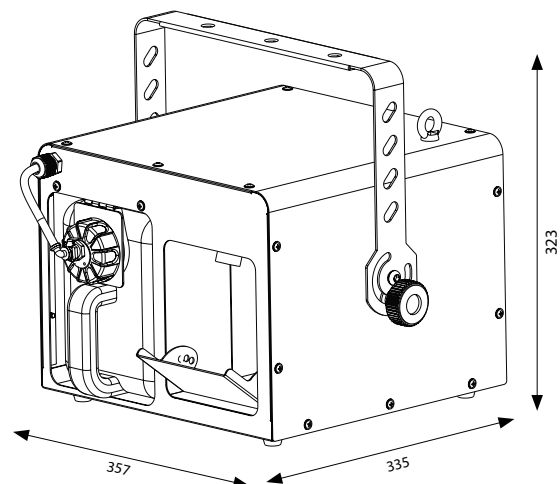



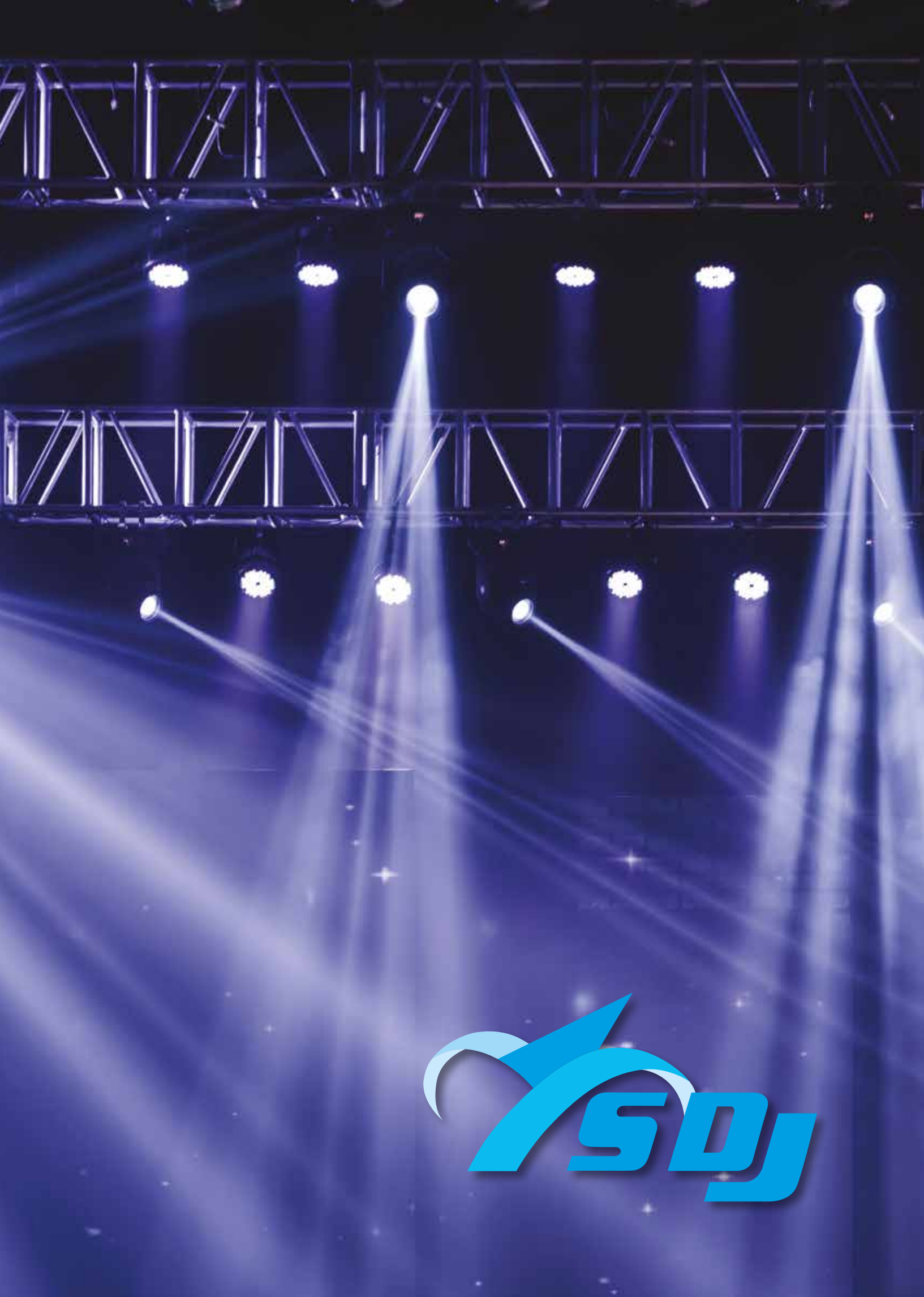



LED MOVING HEADS



NEW

SG SMTDOT - PRODUCT CODE

LIGHT SOURCE

- 1x40W RGBW led high brightness
- 12 RGB led for external ring
- LED lifespan: >50.000h

OPTIC SYSTEM

- Beam angle: 4°

COLOR SYSTEM

- LED source RGBW Full color
- Infinite chromatic possibilities

EFFECTS

- Ring color rainbow effect in both directions with adjustable speed
- Linear dimmer 0-100%
- Electronic high speed strobe from 1 to 20 flashes/s, with adjustable speed.
- Color macros selectable from DMX

CONTROL AND PROGRAMMING

- 2 different DMX channels configurations: 16/30 channels
- Protocol USITT DMX 512
- Master/Slave mode selectable
- Sound mode with adjustable sensitivity of microphone
- Reset via DMX

STRUCTURE AND CABINET

- Black metal Housing, and plastic materials with high resistance
- Red LED display
- Pan 540° / Tilt 210°
- Mounting points: 1 omega holder + safety ring
- 3-poles XLR in/out connection
- IP Rating: IP 20
- Forced air fan cooling system

POWER SUPPLY

- Input Voltage: AC~100-240V 50/60Hz
- Switching power supply unit
- Max Power: 60W @ 230VAC
- Power connection with VDE sockets
- Power supply cable 1,5 mt included

WEIGHT AND DIMENSIONS

- Net weight: 2,4 kg
- Dimensions: 160x160x230mm

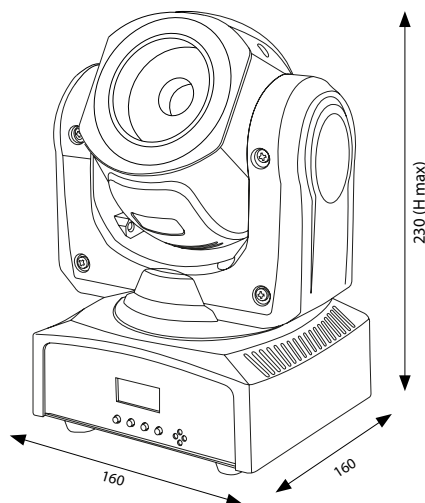



NEW

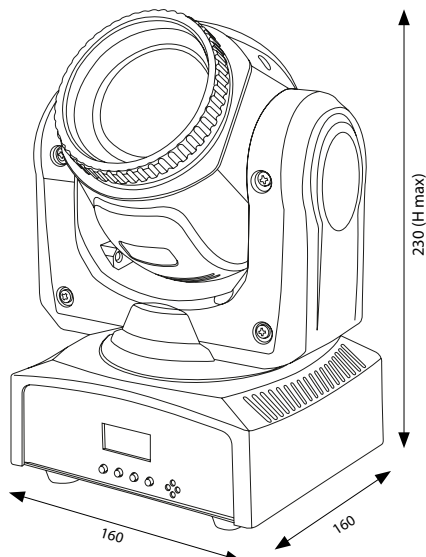

SG SMTBEAM - PRODUCT CODE

LIGHT SOURCE

- 1x40W White led high brightness
- LED lifespan: >50.000h

OPTIC SYSTEM

- Beam angle: 4°
- Manual focus

COLOR SYSTEM

- Color wheel: 11 colors + white

EFFECTS

- Gobo wheel: 11 fixed gobos
- Gobo scroll from slow to fast
- Color rainbow effect with adjustable speed
- Linear dimmer 0-100%
- Electronic high speed strobe from 1 to 20 flashes/s, with adjustable speed.
- Pan/Tilt macros selectable from DMX

CONTROL AND PROGRAMMING

- 2 different DMX channels configurations: 9/11 channels
- Protocol USITT DMX 512
- Master/Slave mode
- Sound mode with adjustable sensitivity of microphone
- Reset via DMX

STRUCTURE AND CABINET

- Black metal Housing, and plastic materials with high resistance
- Red LED display
- Pan 540° / Tilt 210°
- Mounting points: 1 omega holder + safety ring
- 3-poles XLR in/out connection
- IP Rating: IP 20
- Forced air fan cooling system

POWER SUPPLY

- Input Voltage: AC~100-240V 50/60Hz
- Switching power supply unit
- Max Power: 50W @ 230VAC
- Power connection with VDE sockets
- Power supply cable 1,5 mt included

WEIGHT AND DIMENSIONS

- Net weight: 2,4 kg
- Dimensions: 160x160x230mm





SG SMTWHPLUS - PRODUCT CODE

LIGHT SOURCE

- 7x12W led RGBWA Full Color
- LED lifespan: > 50.000h

OPTIC SYSTEM

- Beam Angle: 25°

COLOR SYSTEM

- Led Source 5 in 1 RGBWA Full Color
- Infinite chromatic possibilities

EFFECTS

- Linear dimmer 0-100%
- Adjustable strobe effect
- Color macro selectable from DMX

CONTROL AND PROGRAMMING

- 2 DMX configurations available: 5/14 channels
- Protocol USITT DMX 512
- Master/Slave mode
- Sound mode with adjustable microphone sensitivity
- Auto mode

STRUCTURE AND CABINET

- Black metal housing and high resistance plastic materials
- Red LED display
- Pan angle 540°
- Tilt angle 180°
- Mounting points: 1 omega holder + "safety ring"
- XLR 3-poles DMX IN/OUT connection
- IP rating: IP20
- Forced air cooling system

POWER SUPPLY

- Input Voltage: AC~100-240V, 50/60 Hz
- Switching power supply unit
- Max power: 100W @ 230VAC
- Power supply cable 1mt included

WEIGHT AND DIMENSIONS

- Net weight: 3,5 kg
- Dimensions: 175x175x250 mm

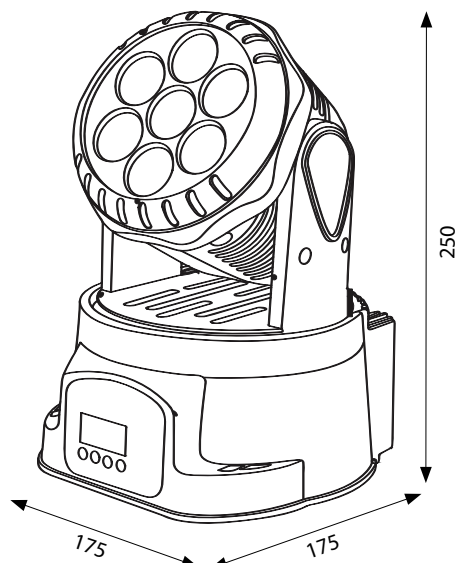

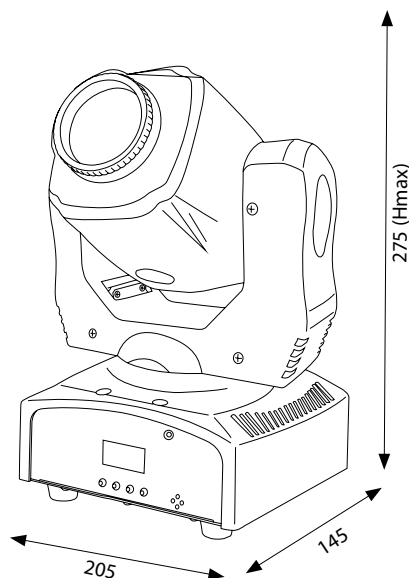

SG SMTSPOTPLUS - PRODUCT CODE

LIGHT SOURCE

- 1x60W white LED high brightness
- LED Color temperature: 5600K
- LED lifespan: >50.000h

OPTIC SYSTEM

- Beam angle: 13°
- Manual focus

COLOR SYSTEM

- Color wheel: 7 colors + white

EFFECTS

- Gobo wheel: 7 fixed gobos that can be combined with color wheel
- Gobo shake
- Gobo scroll in both directions
- Color rainbow effect in both directions with adjustable speed
- Linear dimmer 0-100%
- Electronic high speed strobe from 1 to 20 flashes/s, adjustable speed
- Color and Pan&Tilt macros selectable from DMX

CONTROL AND PROGRAMMING

- 3 different DMX channels configurations: 5/9/11 channels
- Protocol USITT DMX 512
- Pan&Tilt 8/16 bit selectable resolution
- Master/Slave mode
- Sound mode with adjustable sensitivity of microphone
- Reset via DMX

STRUCTURE AND CABINET

- Black metal housing and plastic materials with high resistance
- Blue LED display
- Pan 540° / Tilt 230°
- Mounting points: 1 omega holder
- 3-poles XLR in/out connection
- IP Rating: IP 20
- Forced air fan cooling system

POWER SUPPLY

- Input Voltage: AC~100-240V 50/60Hz
- Switching power supply unit
- Max power: 70W @ 230VAC
- Power connection with VDE sockets
- Power supply cable 1,5 mt included

WEIGHT AND DIMENSIONS

- Net weight: 3,0 kg
- Dimensions: 205x145x275 mm





SG CLSPOT100 - PRODUCT CODE
SG CASECLUB - CASE (4X SG CLSPOT100)

LIGHT SOURCE

- 1x100W white led high brightness
- Color temperature 5600K
- LED lifespan: >50.000h
- LED Refresh frequency: >400Hz flicker-free

OPTIC SYSTEM

- Beam angle: 9,4°
- Electronic focus
- Luminous flux: 3600 lux @5mt (9.4°)

COLOR SYSTEM

- Color wheel with 7 colors + white

EFFECTS

- 7 dichroic rotating gobos, the gobos are interchangeable with the "plug & play" system. Gobo size 21,8mm / focus 14,5mm
- Bidirectional gobo scroll with adjustable speed
- Gobo shake effect
- Gobo Scroll with variable speed
- 3-facet rotating prism with adjustable speed in both directions
- Color rainbow effect in both directions
- Linear dimmer 0 - 100%
- High speed electronic strobe max.25 flashes/s, with adjustable speed
- Random strobe and pulse dimmer effects with adjustable speed

CONTROL AND PROGRAMMING

- 2 DMX configurations available: 11/13 channels
- Protocol USITT DMX 512
- Pan&Tilt 8/16 bit selectable resolution
- Master / Slave mode
- Sound mode with adjustable microphone sensitivity
- Auto mode with 7 internal programs selectable from display
- Reset via DMX

STRUCTURE AND CABINET

- Black aluminium/metal housing and plastic materials with high resistance
- Red LED display
- 3 different Pan&Tilt angle presets: PAN 360°-540°-630°, TILT 90°-180°-270°
- Mounting points: one 1/4-turn lock omega holder
- Automatic repositioning of PAN and TILT after accidental movement
- 3-poles XLR in/out connection
- IP Rating: IP 20
- Forced air fan cooling system with electronic control

POWER SUPPLY

- Input Voltage: AC~100-240V 50/60Hz
- Switching power supply unit
- Max power: 120W @ 230VAC
- IN power connection with powerCON sockets
- Power supply cable 1,5 mt included

WEIGHT AND DIMENSIONS

- Net weight: 6,8 kg
- Dimensions: 270x149x366 mm

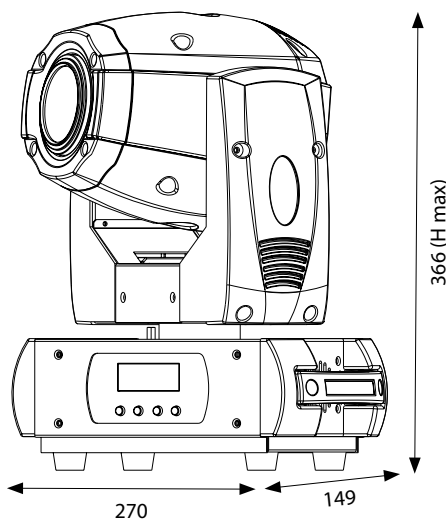



SG CLBEAM100 - PRODUCT CODE
SG CASECLUB - CASE (4X SG CLBEAM100)

LIGHT SOURCE

- 1x100W white led high brightness
- Color temperature 5600K
- LED lifespan: >50.000h
- LED Refresh frequency: >400Hz flicker-free

OPTIC SYSTEM

- Beam angle: 2°
- Electronic focus
- Luminous flux: 21300 lux @5mt (2°)

COLOR SYSTEM

- Color wheel with 14 colors + white

EFFECTS

- Gobo wheel: 17 fixed gobos
- Bidirectional gobo scroll with adjustable speed
- 8-facet rotating prism with adjustable speed
- Color rainbow effect in both directions
- Linear dimmer 0 - 100%
- High speed electronic strobe max.25 flashes/s, adjustable speed
- Random strobe and pulse dimmer effects with adjustable speed

CONTROL AND PROGRAMMING

- 2 DMX configurations available: 10/12 channels
- Protocol USITT DMX 512
- Pan&Tilt 8/16 bit selectable resolution
- Master / Slave mode
- Sound mode with adjustable microphone sensitivity
- Auto mode with 7 internal programs selectable from display
- Reset via DMX

STRUCTURE AND CABINET

- Black aluminium/metal housing and plastic materials with high resistance
- Red LED display
- 3 different Pan&Tilt angle presets: PAN 360°-540°-630°, TILT 90°-180° 270°
- Mounting points: 1 omega holder
- Automatic repositioning of PAN and TILT after accidental movement not controlled by control unit
- 3-poles XLR in/out connection
- IP Rating: IP 20
- Forced air fan cooling system with electronic control

POWER SUPPLY

- Input Voltage: AC~100-240V 50/60Hz
- Switching power supply unit
- Max power: 120W @ 230VAC
- IN power connection with powerCON sockets
- Power supply cable 1,5 mt included

WEIGHT AND DIMENSIONS

- Net weight: 7,3 kg
- Dimensions: 270x149x364 mm

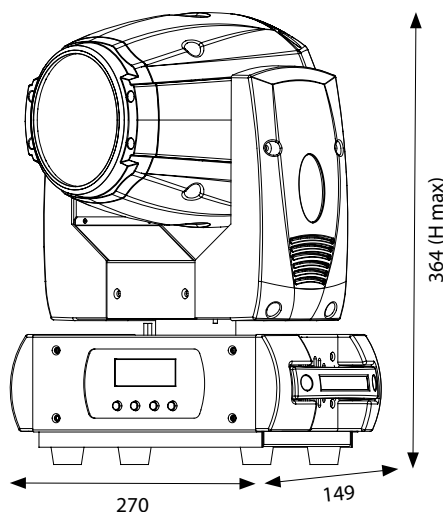



SG CLWASH - PRODUCT CODE

SG CLWASHKIT - KIT (2x SG CLWASH + 1 SG CASESCLWASH)

SG CASESCLWASH - CASE (4x SG CLWASH)

LIGHT SOURCE

- 36x10W led RGBW Full Color
- LED lifespan: > 50.000h
- LED refresh frequency: > 400Hz flicker-free

OPTIC SYSTEM

- Beam Angle: zoom from 8° to 50°
- Luminous flux: 1.130 lux @ 5mt (8°)

COLOR SYSTEM

- LED source RGBW Full color
- Infinite chromatic possibilities

EFFECTS

- Linear dimmer 0-100%
- Electronic high speed strobe from 1 to 25 flashes/s, with adjustable speed.
- Random strobe and pulse effect with adjustable speed
- Color macros selectable via DMX

CONTROL AND PROGRAMMING

- 1 DMX configurations available: 14 channels
- Protocol USITT DMX 512
- Master/Slave mode
- Sound mode with adjustable microphone sensitivity
- Auto mode
- Reset via DMX

STRUCTURE AND CABINET

- Black metal housing and high resistance plastic materials
- Blue LCD graphic display
- Pan angle: 540°
- Tilt angle: 250°
- Mounting points: 1 pair of 1/4-turn lock omega holders
- Automatic repositioning of Pan and Tilt after accidental movements
- XLR 3-poles DMX IN/OUT connection
- IP rating: IP20
- Forced air cooling system with electronic control

POWER SUPPLY

- Input Voltage: AC~100-240V, 50/60 Hz
- Switching power supply unit
- Max power: 370W @ 230VAC
- Power input with PowerCON connector
- Power supply cable 1mt included

WEIGHT AND DIMENSIONS

- Net weight: 9,8 kg
- Dimensions: 335x235x442 mm

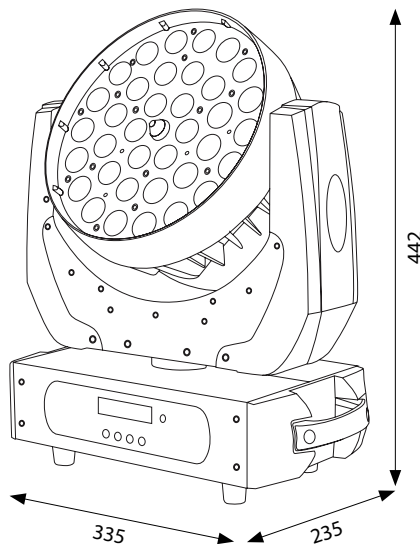



NEW

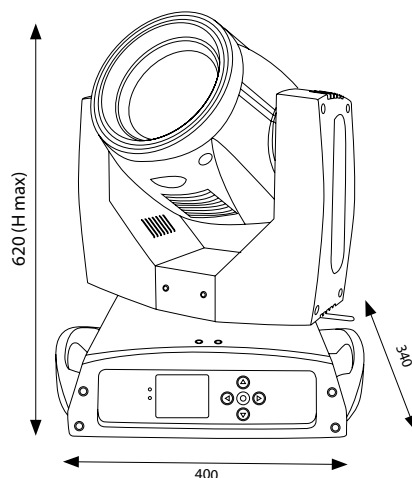

SG CLBEAM7R - PRODUCT CODE

SG CLBEAM7RKIT - KIT (2x SG CLBEAM7R + 1x SG CASECLBEAM7R)

SG CASECLBEAM7R - CASE (2x SG CLBEAM7R)

LIGHT SOURCE

- Osram P-VIP 230W
- Lamp lifespan: 2000h
- Electronic ballast

OPTIC SYSTEM

- Beam Angle: 3,8°
- Electronic focus
- Luminous flux: 41.700 lux @ 20mt

COLOR SYSTEM

- Color wheel with 14 colors + white (2x CTO - CTB)

EFFECTS

- Fixed gobo wheel with 17 gobos and 6 steps "beam reducer"
- Gobo shacking effect
- Gobo scroll effect with adjustable speed
- 8-facet circular rotating prism with adjustable speed
- Color rainbow effect
- Linear dimmer 0-100%
- Adjustable strobe effect
- Random strobe effect

CONTROL AND PROGRAMMING

- 1 DMX configuration available: 16 channels
- Protocol USITT DMX 512
- Built-in analyzer for easy fault finding

STRUCTURE AND CABINET

- Black metal housing and high resistance plastic materials
- Color LCD display
- Pan angle: 540°
- Tilt angle: 270°
- Mounting points: 2 pairs of 1/4-turn locks
- Automatic repositioning of Pan and Tilt after accidental movements
- XLR 3-poles DMX IN/OUT connection
- IP rating: IP20
- Forced air cooling system with electronic control

POWER SUPPLY

- Input Voltage: AC~100-240V, 50/60 Hz
- Switching power supply unit
- Max power: 270W @ 230VAC
- Power input with PowerCON connector
- Power supply cable 1mt included

WEIGHT AND DIMENSIONS

- Net weight: 16,5 kg
- Dimensions 400x340x620mm

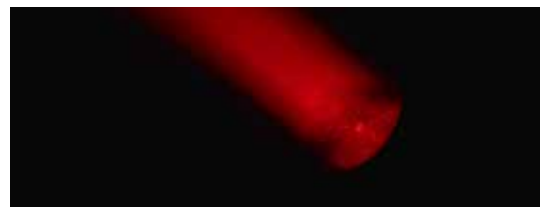



LED PROJECTORS



SG SLIMPAR7DL - PRODUCT CODE

LIGHT SOURCE

- 7x12W led RGBWAW Full Color
- LED lifespan: >50,000h
- LED refresh frequency: >400Hz flicker free

OPTIC SYSTEM

- Beam angle: 25°
- Luminous flux: 2290 lux @3mt (25°)

COLOR SYSTEM

- LED source 6 in 1 RGBWAW Full Color
- Infinite chromatic possibilities and colour temperature control
- Color temperature control with Amber color
- "Dark Light" technology LED UV (Ultra Violet)
- 2 color macros can be recalled by DMX

EFFECTS

- Linear Dimmer 0-100%
- Electronic strobe: 1-20 flashes/s with adjustable speed

CONTROL AND PROGRAMMING

- 4 DMX configurations available: 1/6/7/10 channels
- Protocol USITT DMX 512
- Master / Slave mode
- Sound mode with adjustable mic sensitivity
- Static color mode with independent adjustment of strobe
- Automatic mode with 2 different programs selectable from the display with independent adjustment of the speed and strobe
- Color mode with 50 different pre-programmed color macros with independent adjustment of the strobe
- IR remote controller included with possibility to recall colors or macros

STRUCTURE AND CABINET

- ABS housing, black color
- Red LED display
- Mounting points: double adjustable bracket
- "light up" positioning without brackets
- 3-poles XLR in/out connection
- IP rating: IP 20
- Forced air fan cooling system

POWER SUPPLY

- Input Voltage: AC~100-240V 50/60Hz
- Switching power supply unit
- Max power: 100W @ 230VAC
- Power IN/OUT connection with VDE socket
- Power supply cable 1,5 mt included
- Max 6 pcs linkable @240V

WEIGHT AND DIMENSIONS

- Net weight: 2,1 kg
- Dimensions: 257x130x240 mm

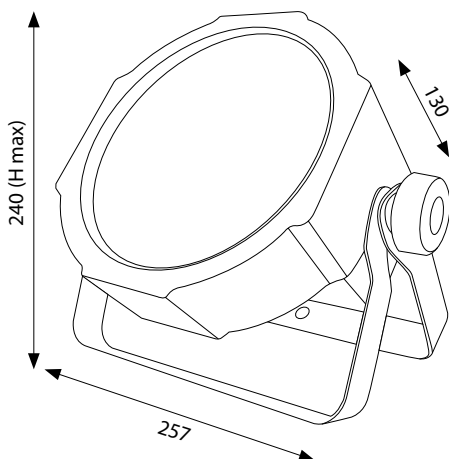

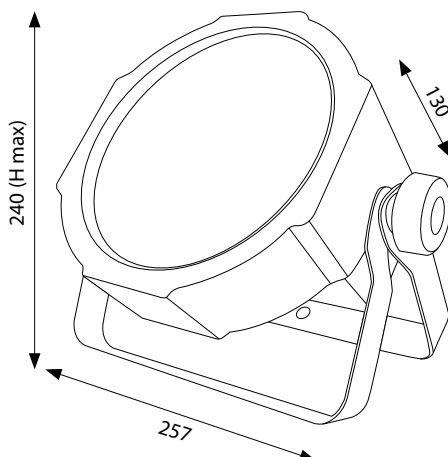

SG SLIMPAR12DL - PRODUCT CODE

LIGHT SOURCE

- 12x12W led RGBWAU Full Color
- LED lifespan: >50.000h
- LED refresh frequency: >400Hz flicker free

OPTIC SYSTEM

- Beam angle: 25°
- Luminous flux: 1210 lux @5mt (25°)

COLOR SYSTEM

- LED source 6 in 1 RGBWAU Full Color
- Infinite chromatic possibilities and colour temperature control
- Color temperature control with Amber color
- "Dark Light" technology LED UV (Ultra Violet)
- 2 color macros can be recalled by DMX

EFFECTS

- Linear Dimmer 0-100%
- Electronic strobe: 1-20 flashes/s with adjustable speed

CONTROL AND PROGRAMMING

- 4 DMX configurations available: 1/6/7/10 channels
- Protocol USITT DMX 512
- Master / Slave mode
- Sound mode with adjustable mic sensitivity
- Static color mode with independent adjustment of strobe
- Automatic mode with 2 different programs selectable from the display with independent adjustment of the speed and strobe
- Color mode with 50 different pre-programmed color macros with independent adjustment of the strobe
- IR remote controller included with possibility to recall colors or macros

STRUCTURE AND CABINET

- ABS housing, black color
- Red LED display
- Mounting points: double adjustable bracket
- "light up" positioning without brackets
- 3-poles XLR in/out connection
- IP rating: IP 20
- Forced air fan cooling system

POWER SUPPLY

- Input Voltage: AC~100-240V 50/60Hz
- Switching power supply unit
- Max power: 160W @ 230VAC
- Power IN/OUT connection with VDE socket
- Power supply cable 1,5 mt included
- Max 4 pcs linkable @240V

WEIGHT AND DIMENSIONS

- Net weight: 2,1 kg
- Dimensions: 257x130x240 mm

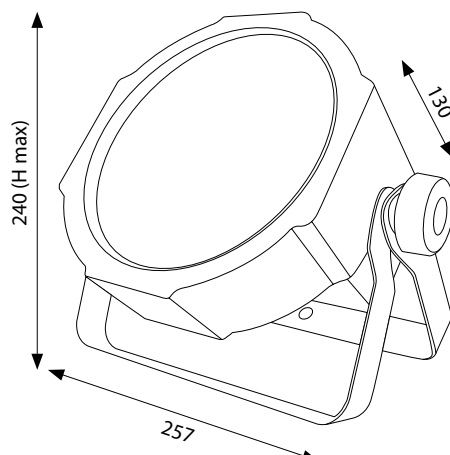

**SG SLIMPAR12 - PRODUCT CODE****LIGHT SOURCE**

- 12x8W led RGBW Full Color
- LED lifespan: >50.000h
- LED refresh frequency: >400Hz flicker free

OPTIC SYSTEM

- Beam angle: 25°
- Luminous flux: 1060 lux @5mt (25°)

COLOR SYSTEM

- LED source 4 in 1 RGBW Full Color
- Infinite chromatic possibilities and colour temperature control
- 2 color macros can be recalled by DMX

EFFECTS

- Linear Dimmer 0-100%
- Electronic strobe: 1-20 flashes/s with adjustable speed

CONTROL AND PROGRAMMING

- 4 DMX configurations available: 1/4/5/8 channels
- Protocol USITT DMX 512
- Master / Slave mode
- Sound mode with adjustable mic sensitivity
- Static color mode with independent adjustment of strobe
- Automatic mode with 2 different programs selectable from the display with independent adjustment of the speed and strobe
- Color mode with 50 different pre-programmed color macros with independent adjustment of the strobe
- IR remote controller included with possibility to recall colors or macros

STRUCTURE AND CABINET

- ABS housing, black color
- Red LED display
- Mounting points: double adjustable bracket
- "light up" positioning without brackets
- 3-poles XLR in/out connection
- IP rating: IP 20
- Forced air fan cooling system

POWER SUPPLY

- Input Voltage: AC~100-240V 50/60Hz
- Switching power supply unit
- Max power: 110W @ 230VAC
- Power IN/OUT connection with VDE socket
- Power supply cable 1,5 mt included
- Max 6 pcs linkable @240V

WEIGHT AND DIMENSIONS

- Net weight: 2,1 kg
- Dimensions: 257x130x240 mm

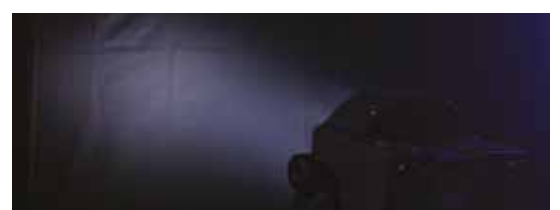

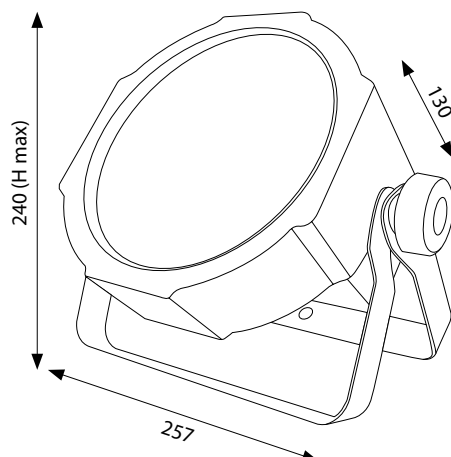
**SG SLIMPAR18 - PRODUCT CODE****LIGHT SOURCE**

- 18x3W led RGB Full Color
- LED lifespan: >50.000h
- LED refresh frequency: >400Hz flicker free

OPTIC SYSTEM

- Beam angle: 25°
- Luminous flux: 1140 lux @5mt (25°)

COLOR SYSTEM

- LED source 3 in 1 RGB Full Color
- Infinite chromatic possibilities and colour temperature control
- 2 color macros can be recalled by DMX

EFFECTS

- Linear Dimmer 0-100%
- Electronic strobe: 1-20 flashes/s with adjustable speed

CONTROL AND PROGRAMMING

- 4 DMX configurations available: 1/3/4/7 channels
- Protocol USITT DMX 512
- Master / Slave mode
- Sound mode with adjustable mic sensitivity
- Static color mode with independent adjustment of strobe
- Automatic mode with 2 different programs selectable from the display with independent adjustment of the speed and strobe
- Color mode with 50 different pre-programmed color macros with independent adjustment of the strobe
- IR remote controller included with possibility to recall colors or macros

STRUCTURE AND CABINET

- ABS housing, black color
- Red LED display
- Mounting points: double adjustable bracket
- "light up" positioning without brackets
- 3-poles XLR in/out connection
- IP rating: IP 20
- Forced air fan cooling system

POWER SUPPLY

- Input Voltage: AC~100-240V 50/60Hz
- Switching power supply unit
- Max power: 70W @ 230VAC
- Power IN/OUT connection with VDE socket
- Power supply cable 1,5 mt included
- Max 6 pcs linkable @240V

WEIGHT AND DIMENSIONS

- Net weight: 2,1 kg
- Dimensions: 257x130x240 mm





SG SLIMPAR18C - PRODUCT CODE

LIGHT SOURCE

- 18x1W led RGB
- LED lifespan: > 50.000h

OPTIC SYSTEM

- Beam Angle: 25°

COLOR SYSTEM

- LED source RGBW (6R - 6G - 6B)
- Infinite chromatic possibilities

EFFECTS

- Linear dimmer 0-100%
- Adjustable strobe effect
- Random strobe effect
- Color macros selectable via DMX

CONTROL AND PROGRAMMING

- 1 DMX configuration available: 6 channels
- Protocol USITT DMX 512
- Master/Slave mode
- Sound mode
- Auto mode
- IR remote controller included with possibility to recall colors or macros

STRUCTURE AND CABINET

- ABS housing black color
- Red LED display
- Mounting points: double adjustable bracket
- "Light-up" positioning without brackets
- XLR 3-poles DMX IN/OUT connection
- IP rating: IP20
- Forced air fan cooling system

POWER SUPPLY

- Input Voltage: AC~100-240V, 50/60 Hz
- Switching power supply unit
- Max power: 25W @ 230VAC
- Power supply cable 1mt included

WEIGHT AND DIMENSIONS

- Net weight: 1,25 kg
- Dimensions: 230x105x200 mm

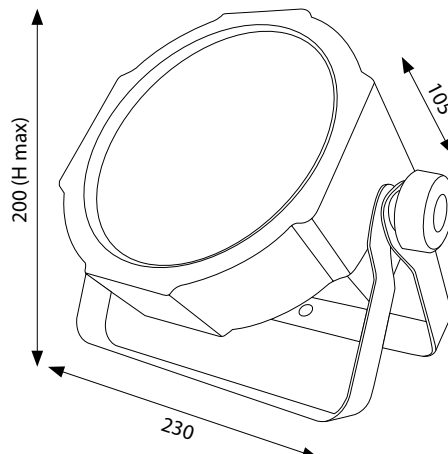

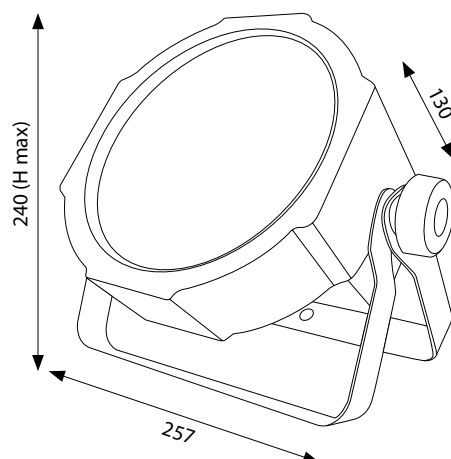
**SG SLIMPARFLC - PRODUCT CODE****LIGHT SOURCE**

- 224x0,5W led Edison 6500K
- LED lifespan: > 50.000h

OPTIC SYSTEM

- Beam Angle: 120°

COLOR SYSTEM

- LED source 224x0,5W led Edison 6500K

EFFECTS

- Linear dimmer 0-100%
- Adjustable strobe effect
- Random strobe effect
- Circular sectors control

CONTROL AND PROGRAMMING

- 7 DMX configurations available: 1/2/4/7/8/9/11 channels
- Protocol USITT DMX 512
- Master/Slave mode
- Sound mode
- Auto mode
- IR remote controller included with possibility to recall colors or macros

STRUCTURE AND CABINET

- ABS housing black color
- Red LED display
- Mounting points: double adjustable bracket
- "Light-up" positioning without brackets
- XLR 3-poles DMX IN/OUT connection
- IP rating: IP20
- Forced air fan cooling system

POWER SUPPLY

- Input Voltage: AC~100-240V, 50/60 Hz
- Switching power supply unit
- Max power: 90W @ 230VAC
- Power supply cable 1mt included

WEIGHT AND DIMENSIONS

- Net weight: 1,5 kg
- Dimensions: 257x130x240 mm

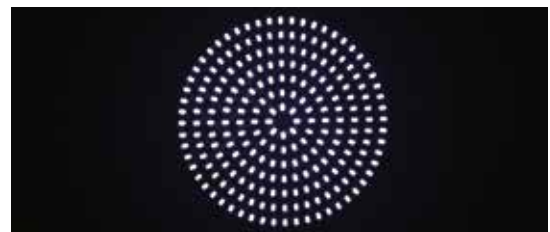



SG SLIMPARCOB30 - PRODUCT CODE

LIGHT SOURCE

- 1x30W RGBW COB led
- LED lifespan: >50.000h
- LED refresh frequency: >400Hz flicker-free

OPTIC SYSTEM

- Beam angle: 50°

COLOR SYSTEM

- RGBW full color mixing
- Infinite chromatic possibilities

EFFECTS

- Fine linear Dimmer 0-100%
- Adjustable strobe 1-10 flash/s

CONTROL AND PROGRAMMING

- 1 DMX configuration available: 7 channels
- Protocol USITT DMX 512
- Master/Slave mode
- Sound Mode
- Automatic mode
- IR remote controller included with possibility to recall colors or macros

STRUCTURE AND CABINET

- High resistance ABS housing, black color
- Red led display
- Mounting points: double adjustable bracket system
- "Light-up" positioning without brackets
- 3 poles XLR in-out dmx signal connection
- IP20 protection grade
- Forced air fan cooling system

POWER SUPPLY

- Input Voltage: AC~100-240V, 50/60 Hz
- Switching power supply unit
- Max power: 35W @ 230VAC
- Power supply cable included

WEIGHT AND DIMENSIONS

- Net weight: 1,9 kg
- Dimensions: 260x180x240 mm

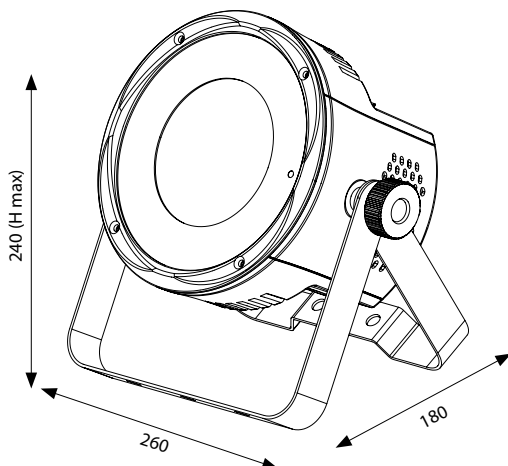



SG SLIMPARCOB60 - PRODUCT CODE

LIGHT SOURCE

- 1x60W RGBW COB led
- LED lifespan: >50.000h
- LED refresh frequency: >400Hz flicker-free

OPTIC SYSTEM

- Beam angle: 50°

COLOR SYSTEM

- RGBW full color mixing
- Infinite chromatic possibilities

EFFECTS

- Fine linear Dimmer 0-100%
- Adjustable strobe 1-10 flash/s

CONTROL AND PROGRAMMING

- 1 DMX configuration available: 7 channels
- Protocol USITT DMX 512
- Master/Slave mode
- Sound Mode
- Automatic mode
- IR remote controller included with possibility to recall colors or macros

STRUCTURE AND CABINET

- High resistance ABS housing, black color
- Red led display
- Mounting points: double adjustable bracket system
- "Light-up" positioning without brackets
- 3 poles XLR in-out dmx signal connection
- IP20 protection grade
- Forced air fan cooling system

POWER SUPPLY

- Input Voltage: AC~100-240V, 50/60 Hz
- Switching power supply unit
- Max power: 65W @ 230VAC
- Power supply cable included

WEIGHT AND DIMENSIONS

- Net weight: 1,9 kg
- Dimensions: 260x180x240 mm

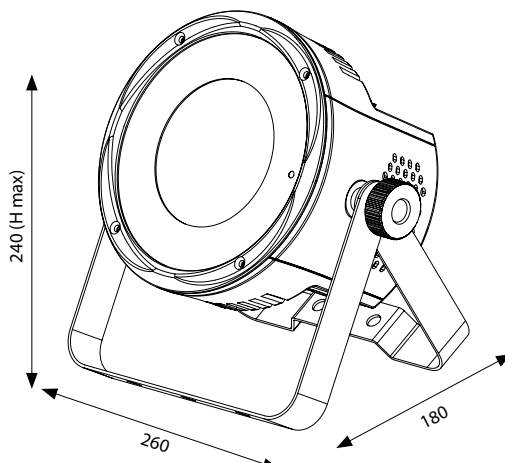



SG SLIMPARCOB100 - PRODUCT CODE

LIGHT SOURCE

- 1x100W RGBW COB led
- LED lifespan: >50.000h
- LED refresh frequency: >400Hz flicker-free

OPTIC SYSTEM

- Beam angle: 50°

COLOR SYSTEM

- RGBW full color mixing
- Infinite chromatic possibilities

EFFECTS

- Fine linear Dimmer 0-100%
- Adjustable strobe 1-10 flash/s

CONTROL AND PROGRAMMING

- 1 DMX configuration available: 7 channels
- Protocol USITT DMX 512
- Master/Slave mode
- Sound Mode
- Automatic mode
- IR remote control
- IR remote controller included with possibility to recall colors or macros

STRUCTURE AND CABINET

- High resistance ABS housing, black color
- Red led display
- Mounting points: double adjustable bracket system
- "Light-up" positioning without brackets
- 3 poles XLR in-out dmx signal connection
- IP20 protection grade
- Forced air fan cooling system

POWER SUPPLY

- Input Voltage: AC~100-240V, 50/60 Hz
- Switching power supply unit
- Max power: 105W @ 230VAC
- Power supply cable included

WEIGHT AND DIMENSIONS

- Net weight: 1,9 kg
- Dimensions: 260x180x240 mm

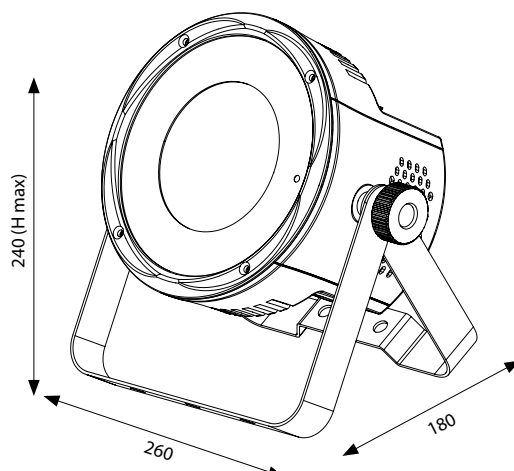

SLIMPAR 6 BATTERY



NEW

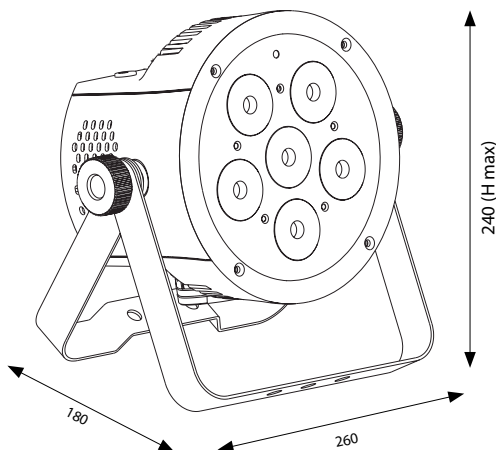

SG SLIMPAR6BAT - PRODUCT CODE
SG CASESLIMPARBAT - CASE (6X SG SLIMPAR6BAT)

LIGHT SOURCE

- 6x10W led RGBW Full Color
- LED lifespan: >50.000h
- LED refresh frequency: >400Hz flicker free

OPTIC SYSTEM

- Beam angle: 15°
- Luminous flux: 1005 lux @5mt (full on)

COLOR SYSTEM

- LED source 4 in 1 RGBW Full Color
- Infinite chromatic possibilities

EFFECTS

- Linear Dimmer 0-100%
- Electronic strobe: 1-20 flashes/s with adjustable speed

CONTROL AND PROGRAMMING

- 3 DMX configurations available: 1/4/7 channels
- Protocol USITT DMX 512
- Built-in DMX wireless (DMX wireless transmitter SG AIRBOX, sold separately)
- Master / Slave mode
- Sound mode with 2 different programs and adjustable mic sensitivity
- Static color mode with strobe adjustment
- Automatic mode with 5 different programs selectable from the display with speed adjustment
- Color mode with 51 different pre-programmed color macros
- IR remote controller included

STRUCTURE AND CABINET

- ABS housing, black color
- Red LED display
- Mounting points: double adjustable bracket
- "light up" positioning without brackets
- 3-poles XLR in/out connection
- IP rating: IP 20

POWER SUPPLY

- Input Voltage: AC~100-240V 50/60Hz for normal working and battery recharge
- Switching power supply unit
- Internal rechargeable battery: 12,6VDC
- Capacity: 10 Ah
- Runtime battery: ~ 5 hrs (full ON)
- Charging cycle: ~ 8 hrs (Projector off)
- Max power: 48W @ 230VAC
- Power IN/OUT connection with VDE socket
- Power supply cable 1,5 mt included

WEIGHT AND DIMENSIONS

- Net weight: 2,5 kg
- Dimensions: 260x180x240 mm





STAGE LEDS



SG HTZLEDC - PRODUCT CODE
SG CASEHTZ - CASE (6X SG HTZLEDC)

LIGHT SOURCE

- 18x8W led RGBW Full Color
- LED lifespan: >50.000h
- LED refresh frequency: >400Hz flicker free

OPTIC SYSTEM

- Beam angle: zoom from 15° to 60°
- Luminous flux: 2250 lux @3mt (15°)

COLOR SYSTEM

- LED source 4 in 1 RGBW Full Color
- Infinite chromatic possibilities and colour temperature control
- Color macros can be recalled by DMX

EFFECTS

- Linear Dimmer 0-100%
- Electronic strobe: 1-25 flashes/s with adjustable speed

CONTROL AND PROGRAMMING

- 6 DMX configurations available: 5/6/6/7/3/13 channels
- 4 selectable dimmer curves
- Protocol USITT DMX 512
- Master / Slave mode
- Sound mode with adjustable mic sensitivity
- Static color mode with independent adjustment of strobe
- Automatic mode with 10 different programs selectable from the display with independent adjustment of the speed and strobe
- Color mode with different pre-programmed color macros

STRUCTURE AND CABINET

- Die cast aluminium black color
- Red LED display
- Mounting points: double adjustable bracket
- 3-poles XLR in/out connection
- IP rating: IP 20
- Forced air fan cooling system

POWER SUPPLY

- Input Voltage: AC~100-240V 50/60Hz
- Switching power supply unit
- Max power: 160W @ 230VAC

WEIGHT AND DIMENSIONS

- Net weight: 4 kg
- Dimensions: 310x216x325 mm

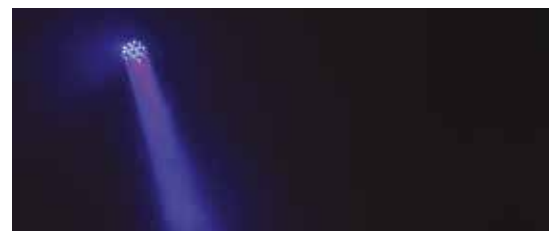
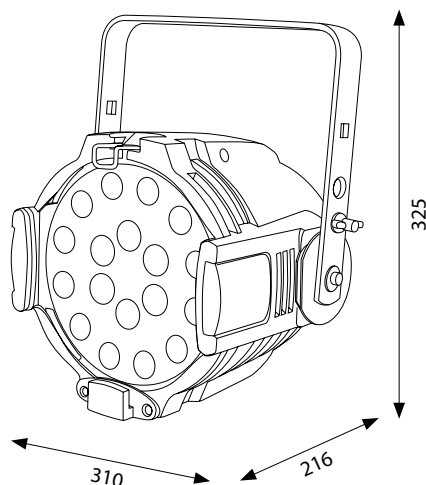

HTZ LED COB WHITE



NEW

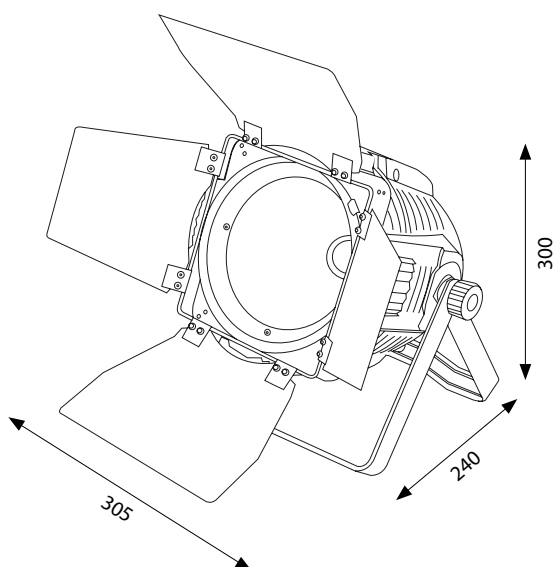

SG HTZLEDCOBW - PRODUCT CODE
SG CASEHTZCOB - CASE (6X SG HTZLEDCOBW)

LIGHT SOURCE

- 1X200W COB led Warm white 3200K
- LED lifespan: >50.000h
- LED refresh frequency: >400Hz flicker free

OPTIC SYSTEM

- Beam angle: 60°
- Luminous flux: 585 lux @ 5m

COLOR SYSTEM

- LED source COB warm white 3200K

EFFECTS

- High precision linear Dimmer 0-100%
- Electronic strobe: 1-20 flashes/s with adjustable speed

CONTROL AND PROGRAMMING

- 2 DMX configurations available: 1/2 channels
- Protocol USITT DMX 512
- Master / Slave mode

STRUCTURE AND CABINET

- Aluminium, black color
- Red LED display
- Barndoor included
- Mounting points: double bracket for suspension or floor support
- 3-poles XLR in/out connection
- IP rating: IP 20
- Forced air fan cooling system

POWER SUPPLY

- Input Voltage: AC~100-240V 50/60Hz
- Switching power supply unit
- Max power: 260W @ 230VAC
- Power IN/OUT with powerCON connector
- Power supply cable 1,5 mt included

WEIGHT AND DIMENSIONS

- Net weight: 3,6 kg
- Dimensions: 305x240x300 mm





NEW

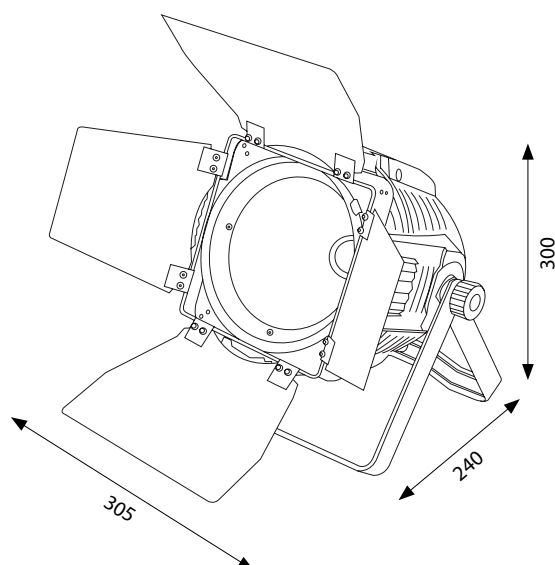

SG HTZLEDCOBC - PRODUCT CODE
SG CASEHTZCOB - CASE (6X SG HTZLEDCOBC)

LIGHT SOURCE

- 1X200W COB led RGBW
- LED lifespan: >50.000h
- LED refresh frequency: >400Hz flicker free

OPTIC SYSTEM

- Beam angle: 60°
- Luminous flux: 405 lux @ 5mt (full on)

COLOR SYSTEM

- LED source 4 in 1 RGBW Full Color
- Infinite chromatic possibilities

EFFECTS

- High precision linear Dimmer 0-100%
- Electronic strobe: 1-20 flashes/s with adjustable speed

CONTROL AND PROGRAMMING

- 2 DMX configurations available: 4/8 channels
- Protocol USITT DMX 512
- Master / Slave mode
- Sound mode
- Color mode with macros and 11 different white temperature programs
- Automatic mode with 10 different programs selectable from the display with speed adjustment

STRUCTURE AND CABINET

- Aluminium, black color
- Red LED display
- Barndoors included
- Mounting points: double bracket for suspension or floor support
- 3-poles XLR in/out connection
- IP rating: IP 20
- Forced air fan cooling system

POWER SUPPLY

- Input Voltage: AC~100-240V 50/60Hz
- Switching power supply unit
- Max power: 260W @ 230VAC
- Power IN/OUT with powerCON connector
- Power supply cable 1,5 mt included

WEIGHT AND DIMENSIONS

- Net weight: 3,6 kg
- Dimensions: 305x240x300 mm





LED BATTERY PROJECTORS



NEW

SG BATI4DLH - PRODUCT CODE

SG BATI4TX - DMX WIRELESS TRANSMITTER

SG BATI4DLHKIT - KIT (8X SG BATI4DLH + 1X SG CASEBATI4DLH)

SG CASEBATI4DLH - CASE WITH CHARGE SYSTEM (8X SG BATI4DLH)

SG BAGBATI4DLH - SOFT BAG (4X SG BATI4DLH)

SG CVMBATI4DLH - MIRROR COVER FOR SG BATI4DLH

SG CVWBATI4DLH - WHITE COVER FOR SG BATI4DLH

SG CVRBATI4DLH - RAIN COVER FOR SG BATI4DLH

LIGHT SOURCE

- 4x12W led RGBWA-UV
- LED lifespan: > 50.000h
- LED refresh frequency: > 400Hz flicker-free

OPTIC SYSTEM

- Beam Angle: 15°

COLOR SYSTEM

- LED source RGBWA-UV
- Infinite chromatic possibilities

EFFECTS

- Linear dimmer 0-100%
- Adjustable strobe effect
- Static color mode: manual adjustment for each color
- Manual color mode: static built-in color macros
- Auto mode: built-in automatic programs with adjustable speed
- Sound mode: sound activation with internal microphone with adjustable sensitivity

CONTROL AND PROGRAMMING

- 3 DMX configurations available: 6/6b/10 channels
- Protocol USITT DMX 512
- Built-in Wi-Fi protocol for direct control by smartphone with App
- Built-in DMX wireless transceiver (DMX wireless transmitter SG BATI4TX, sold separately)
- Remote controller included
- Master/Slave mode
- Auto mode

STRUCTURE AND CABINET

- Metal housing
- LCD color graphic display
- "Light up" positioning with adjustable angle
- IP rating: IP20
- 3-poles DMX IN/OUT
- Convection cooling system without fans

POWER SUPPLY

- Input Voltage: AC~100-240V, 50/60 Hz, for normal working and battery recharge
- Switching power supply unit
- Internal rechargeable battery: 14,8VDC
- Capacity: 7,8 Ah
- Runtime battery: ~ 5 hrs (full ON)
- Charging cycle: ~ 5 hrs (Projector off)
- Power consumption: 50W @ 230VAC
- Power IN/OUT connection with powerCON socket

WEIGHT AND DIMENSIONS

- Net weight: 3,5 kg
- Dimensions: 140x140x205 mm

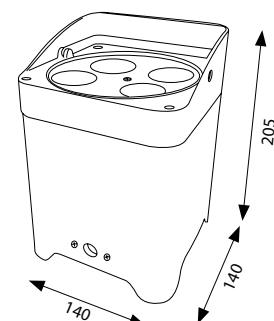



LED BARS



SG SLIMBAR12P - PRODUCT CODE
SG CASESLIMBAR16DL - CASE (4X SG SLIMBAR12P)

LIGHT SOURCE

- 12x15W led RGBW Full Color
- LED lifespan: >50.000h
- LED refresh frequency: >400Hz flicker free

OPTIC SYSTEM

- Beam angle: 10° x 45°
- Luminous flux: 1420 lux @5mt

COLOR SYSTEM

- LED source 4 in 1 RGBW Full Color
- Infinite chromatic possibilities and colour temperature control

EFFECTS

- Linear Dimmer 0-100%
- Electronic strobe: 1-20 flashes/s with adjustable speed
- Color macros selectable by DMX
- Single pixel control

CONTROL AND PROGRAMMING

- 7 DMX configurations available in: 3/4/5/8/10/48/52 channels
- Protocol USITT DMX 512
- Master / Slave mode
- Sound mode with adjustable mic sensitivity
- Static color mode with independent adjustment of strobe
- Automatic mode with 12 different programs selectable from the display with independent adjustment of the speed and strobe
- Color mode with 51 different pre-programmed color macros with independent adjustment of the strobe
- IR remote controller included with possibility to select colors or macros (Included)

STRUCTURE AND CABINET

- Aluminum housing, black color
- color LCD graphic display
- Mounting points: double adjustable bracket on the left and right. Single central bracket for suspension
- "Light up" positioning with angle adjustment
- 3-poles XLR in/out connection
- IP rating: IP 20
- Forced air fan cooling system with electronic control

POWER SUPPLY

- Input Voltage: AC~100-240V 50/60Hz
- Switching power supply unit
- Max power: 190W @ 230VAC
- Power IN/OUT connection with powerCON socket
- Power supply cable 1,5 mt included
- Max 4 pcs linkable @240V

WEIGHT AND DIMENSIONS

- Net weight: 5,1 kg
- Dimensions: 1010x140x160 mm

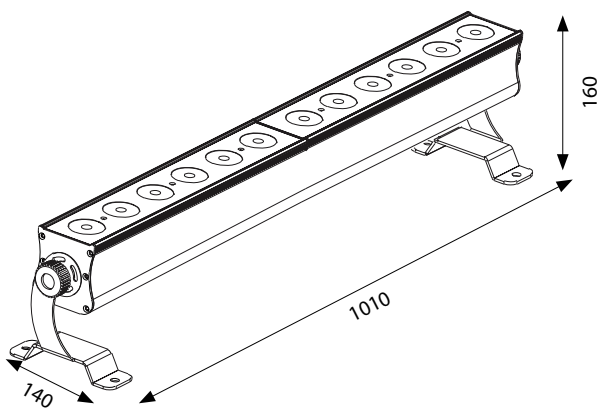

SLIMBAR 8 DL



SG SLIMBAR8DL - PRODUCT CODE
SG CASESLIMBAR8DL - CASE (6X SG SLIMBAR8DL)

LIGHT SOURCE

- 8x12W led RGBWAU Full Color
- LED lifespan: >50.000h
- LED refresh frequency: >400Hz flicker free

OPTIC SYSTEM

- Beam angle: 25°
- Luminous flux: 2290 lux @3mt (25°)

COLOR SYSTEM

- LED source 6 in 1 RGBWAU Full Color
- Infinite chromatic possibilities and colour temperature control
- Color temperature control with Amber color
- "Dark Light" technology LED UV (Ultra Violet)
- 2 color macros can be recalled by DMX

EFFECTS

- Linear Dimmer 0-100%
- Electronic strobe: 1-20 flashes/s with adjustable speed

CONTROL AND PROGRAMMING

- 6 DMX configurations available: 1/6/10/12/24/28 channels
- "Double pixel" control system
- Protocol USITT DMX 512
- Master / Slave mode
- Sound mode with adjustable mic sensitivity
- Static color mode with independent adjustment of strobe
- Automatic mode with 12 different programs selectable from the display with independent adjustment of the speed and strobe
- Color mode with 69 different pre-programmed color macros with independent adjustment of the strobe
- IR remote controller included with possibility to recall colors or macros

STRUCTURE AND CABINET

- Aliminum housing, black color
- Blue LCD graphic display
- Mounting points: double adjustable bracket ok the left and right. Single central bracket for suspension
- "light up" positioning with angle adjustment
- 3-poles XLR in/out connection
- IP rating: IP 20
- Forced air fan cooling system with electronic control

POWER SUPPLY

- Input Voltage: AC~100-240V 50/60Hz
- Switching power supply unit
- Max power: 110W @ 230VAC
- Power IN/OUT connection with powerCON socket
- Power supply cable 1,5 mt included
- Max 6 pcs linkable @240V

WEIGHT AND DIMENSIONS

- Net weight: 3,6 kg
- Dimensions: 505x140x160 mm

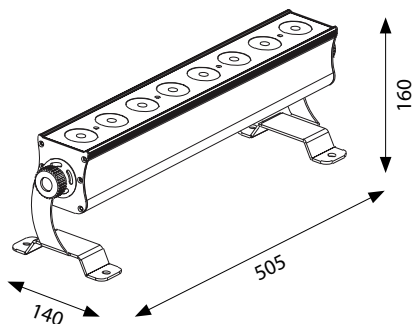



SG SLIMBAR16DL - PRODUCT CODE
SG CASESLIMBAR16DL - CASE (4X SG SLIMBAR16DL)

LIGHT SOURCE

- 16x12W led RGBWAU Full Color
- LED lifespan: >50.000h
- LED refresh frequency: >400Hz flicker free

OPTIC SYSTEM

- Beam angle: 25°
- Luminous flux: 1390 lux @5mt (25°)

COLOR SYSTEM

- LED source 6 in 1 RGBWAU Full Color
- Infinite chromatic possibilities and colour temperature control
- Color temperature control with Amber color
- "Dark Light" technology LED UV (Ultra Violet)
- 2 color macros can be recalled by DMX

EFFECTS

- Linear Dimmer 0-100%
- Electronic strobe: 1-20 flashes/s with adjustable speed

CONTROL AND PROGRAMMING

- 7 DMX configurations available: 1/6/10/12/28/48/52 channels
- "Double pixel" control system
- Protocol USITT DMX 512
- Master / Slave mode
- Sound mode with adjustable mic sensitivity
- Static color mode with independent adjustment of strobe
- Automatic mode with 12 different programs selectable from the display with independent adjustment of the speed and strobe
- Color mode with 69 different pre-programmed color macros with independent adjustment of the strobe
- IR remote controller included with possibility to recall colors or macros

STRUCTURE AND CABINET

- Aluminum housing, black color
- Blue LCD graphic display
- Mounting points: double adjustable bracket on the left and right. Single central bracket for suspension
- "light up" positioning with angle adjustment
- 3-poles XLR in/out connection
- IP rating: IP 20
- Forced air fan cooling system with electronic control

POWER SUPPLY

- Input Voltage: AC~100-240V 50/60Hz
- Switching power supply unit
- Max power: 210W @ 230VAC
- Power IN/OUT connection with powerCON socket
- Power supply cable 1,5 mt included
- Max 4 pcs linkable @240V

WEIGHT AND DIMENSIONS:

- Net weight: 5,1 kg
- Dimensions: 1010x140x160 mm

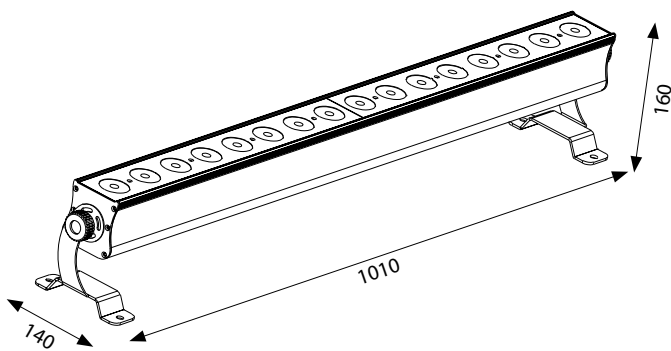

SLIMBAR 240

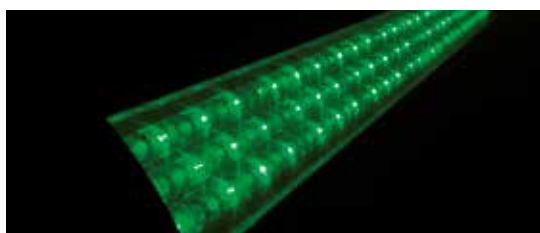
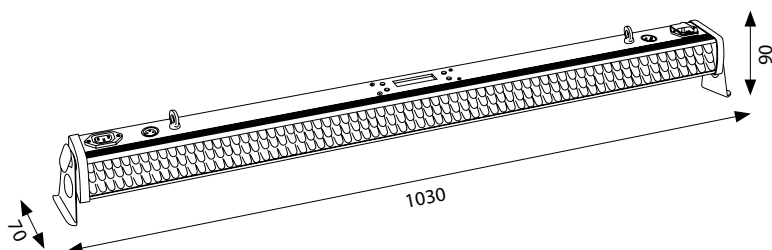

SG SLIMBAR240 - PRODUCT CODE

LIGHT SOURCE

- 240 led 10 mm RGB
- LED lifespan: >50.000h
- LED refresh frequency: >400Hz flicker free

OPTIC SYSTEM

- Beam angle: 30°

COLOR SYSTEM

- LED source RGB
- Infinite chromatic possibilities and colour temperature control
- 1 color macro can be recalled by DMX

EFFECTS

- Linear Dimmer 0-100%
- Electronic strobe: 1-20 flashes/s with adjustable speed

CONTROL AND PROGRAMMING

- 6 DMX configurations available: 3/5/8/14/24/26 channels
- 8-sectors control system
- Protocol USITT DMX 512
- Master / Slave mode
- Sound mode with adjustable mic sensitivity
- Automatic mode with 3 different programs selectable from the display with independent adjustment of the speed
- Color mode with 9 different pre-programmed color macros and 1 adjustable color macro
- IR remote controller included with possibility to recall colors or macros

STRUCTURE AND CABINET

- Aluminum housing, black color
- Red LED display
- Mounting points: double adjustable bracket on the left and right
- "Light up" positioning with angle adjustment
- 3-poles XLR in/out connection
- IP rating: IP 20

POWER SUPPLY

- Input Voltage: AC~100-240V 50/60Hz
- Switching power supply unit
- Max power: 35W @ 230VAC
- Power IN/OUT connection with VDE socket
- Power supply cable 1,5 mt included
- Max 12 pcs linkable @240V

WEIGHT AND DIMENSIONS:

- Net weight: 1,6 kg
- Dimensions: 1030x70x90 mm

SLIMBAR 8 BATTERY



NEW

SG SLIMBAR8BAT - PRODUCT CODE
SG CASESLIMBARBAT - CASE (5X SG SLIMBAR8BAT)

LIGHT SOURCE

- 8x10W led RGBW Full Color
- LED lifespan: >50.000h
- LED refresh frequency: >400Hz flicker free

OPTIC SYSTEM

- Beam angle: 10°x40°

COLOR SYSTEM

- LED source 4 in 1 RGBW Full Color
- Infinite chromatic possibilities

EFFECTS

- Linear Dimmer 0-100%
- Electronic strobe: 1-20 flashes/s with adjustable speed

CONTROL AND PROGRAMMING

- 3 DMX configurations available: 1/4/7 channels
- Protocol USITT DMX 512
- Built-in DMX wireless (DMX wireless transmitter SG AIRBOX, sold separately)
- Master / Slave mode
- Sound mode with 3 different programs and adjustable mic sensitivity
- Static color mode with strobe adjustment
- Automatic mode with 6 different programs selectable from the display with independent adjustment of the speed
- Color mode with 51 different pre-programmed color macros
- IR remote controller included

STRUCTURE AND CABINET

- Metal housing, black color
- Blue LCD graphic display
- Mounting points: double bracket.
- "Light up" positioning with angle adjustment
- 3-poles XLR in/out connection
- IP rating: IP 20
- Convection cooling system without fans

POWER SUPPLY

- Input Voltage: AC~100-240V 50/60Hz for normal working and battery recharge
- Switching power supply unit
- Internal rechargeable battery: 12,6VDC
- Capacity: 10 Ah
- Runtime battery: ~ 5 h (full ON)
- Charging cycle: ~ 8 h (Projector off)
- Max Power: 80W @ 230VAC
- Power IN/OUT connection with powerCON socket
- Power supply cable 1,5 mt included

WEIGHT AND DIMENSIONS

- Net weight: 3,6 kg
- Dimensions: 565x140x190

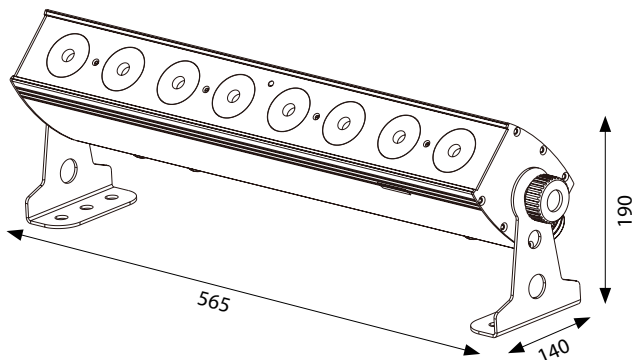

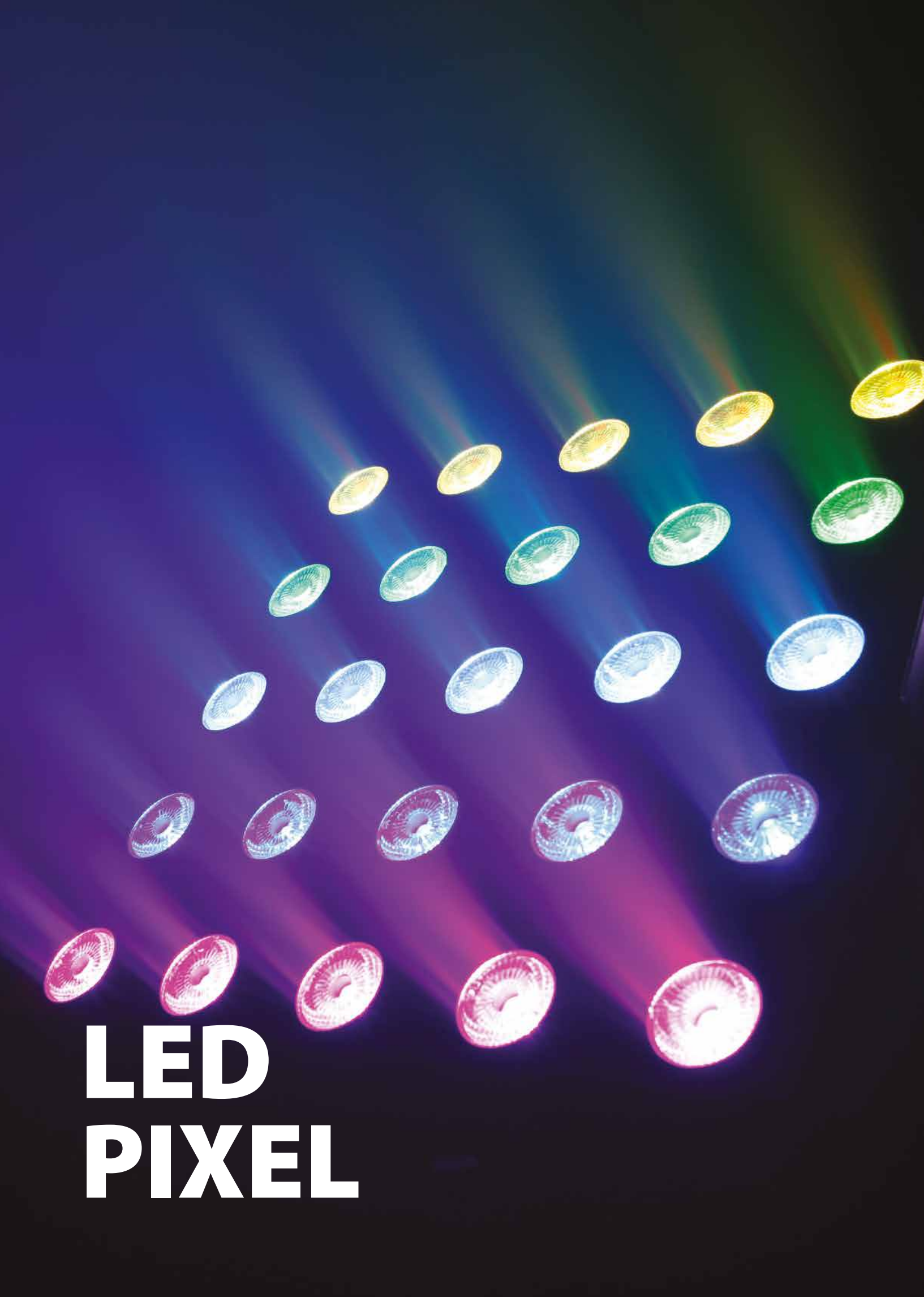

LED PIXEL



SG PIX15 - PRODUCT CODE
SG CASEPIX15 - CASE (6x SG PIX15)

LIGHT SOURCE

- 25x10W led RGBW Full Color
- LED lifespan: >50.000h
- LED refresh frequency: >400Hz flicker free

OPTIC SYSTEM

- Beam angle: 15°
- Luminous flux: 2130 lux @5mt (15°)
- DC (dark cover) optical insulation system

COLOR SYSTEM

- LED source 4 in 1 RGBW Full Color
- Infinite chromatic possibilities
- Color macros can be recalled by DMX

EFFECTS

- Linear Dimmer 0-100%
- Electronic strobe: 1-20 flashes/s with adjustable speed
- Color macros and pixel can be recalled by DMX

CONTROL AND PROGRAMMING

- 5 DMX configurations available: 4/6/8/10/100 channels
- Pixel to pixel control
- 3 selectable dimmer curve
- Protocol USITT DMX 512
- Master / Slave mode
- Sound mode with adjustable mic sensitivity
- Static color mode with independent adjustment of strobe
- Automatic mode with 19 different programs selectable from the display with independent adjustment of the speed

STRUCTURE AND CABINET

- Aluminum housing, black color
- LCD color display
- Mounting points: double central adjustable bracket
- Specific hardware for connection between panels
- 3-poles XLR in/out connection
- IP rating: IP 20
- Fan cooling system without fans

POWER SUPPLY

- Input Voltage: AC~100-240V 50/60Hz
- Switching power supply unit
- Max power: 280W @ 230VAC
- Power IN/OUT connection with powerCON socket
- Power supply cable 1,5 mt included
- Max 6 pcs linkable @240V

WEIGHT AND DIMENSIONS:

- Net weight: 6,8 kg
- Dimensions: 399x113x399 mm

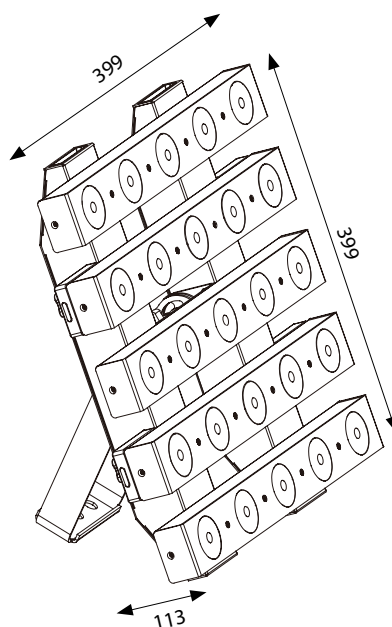
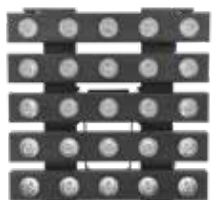



SG PIX15W - PRODUCT CODE
SG CASEPIX15 - CASE (6x SGPIX15W)

LIGHT SOURCE

- 25x3W CREE XPE led Warm White 2800K
- LED lifespan: >50.000h
- LED refresh frequency: >400Hz flicker free

OPTIC SYSTEM

- Beam angle: 5°
- Luminous flux: 7750 lux @5mt (15°)
- DC (dark cover) optical insulation system

COLOR SYSTEM

- LED source CREE Warm White 2800K

EFFECTS

- Linear Dimmer 0-100%
- Electronic strobe: 1-20 flashes/s with adjustable speed
- Color macros and pixel can be recalled by DMX

CONTROL AND PROGRAMMING

- 4 DMX configurations available: 1/2/6/25 channels
- 3 selectable dimmer curves
- Pixel to pixel control
- Protocol USITT DMX 512
- Master / Slave mode
- Sound mode with adjustable mic sensitivity
- Static color mode with independent adjustment of strobe
- Automatic mode with 120 different programs selectable from the display with independent adjustment of the speed

STRUCTURE AND CABINET

- Aluminum housing, black color
- LCD color display
- Mounting points: double central adjustable bracket
- Specific hardware for connection between panels
- 3-poles XLR in/out connection
- IP rating: IP 20
- Fan cooling system without fans

POWER SUPPLY

- Input Voltage: AC~100-240V 50/60Hz
- Switching power supply unit
- Max power: 80W @ 230VAC
- Power IN/OUT connection with powerCON socket
- Power supply cable 1,5 mt included
- Max 8 pcs linkable @240V

WEIGHT AND DIMENSIONS:

- Net weight: 6,8 kg
- Dimensions: 399x113x399 mm

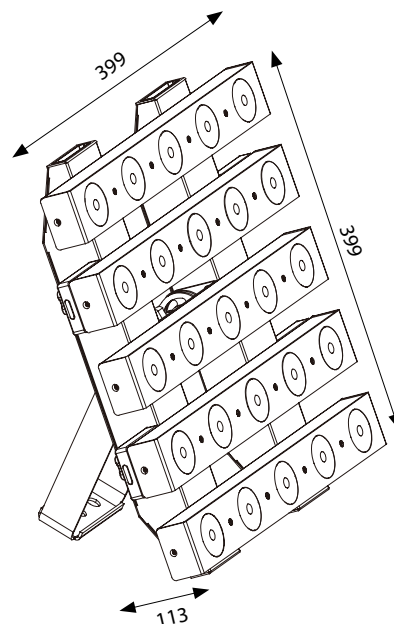
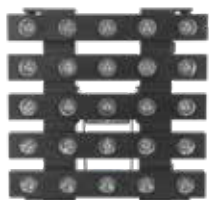



SG PIX15WL - PRODUCT CODE
SG CASEPIX15WL - CASE (8X SG PIX15WL)

LIGHT SOURCE

- 12x3W CREE XPE led Warm White 2800K
- LED lifespan: >50.000h
- LED refresh frequency: >400Hz flicker free

OPTIC SYSTEM

- Beam angle: 5°
- Luminous flux: 3850lux @ 4m
- DC (dark cover) optical insulation system

COLOR SYSTEM

- LED source CREE Warm White 2800K

EFFECTS

- Linear Dimmer 0-100%
- Electronic strobe: 1-20 flashes/s with adjustable speed
- Color macros and pixel can be recalled by DMX

CONTROL AND PROGRAMMING

- 4 DMX configurations available: 2/3/6/12 channels
- 3 selectable dimmer curves
- Pixel to pixel control
- Protocol USITT DMX 512
- Master / Slave mode
- Sound mode with adjustable mic sensitivity
- Static color mode with independent adjustment of strobe
- Automatic mode with independent adjustment of the speed

STRUCTURE AND CABINET

- Aluminum housing, black color
- LCD color display
- Mounting points: central bracket
- Specific hardware for connection between panels
- 3-poles XLR in/out connection
- IP rating: IP 20
- Fan cooling system without fans

POWER SUPPLY

- Input Voltage: AC~100-240V 50/60Hz
- Switching power supply unit
- Max power: 40W @ 230VAC
- Power IN/OUT connection with powerCON socket
- Power supply cable 1,5 mt included
- Max 20 pcs linkable @240V

WEIGHT AND DIMENSIONS:

- Net weight: 2,5 kg
- Dimensions: 1000x55x142 mm

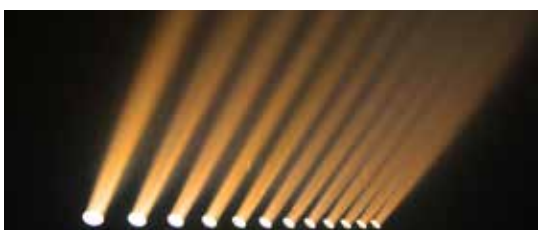
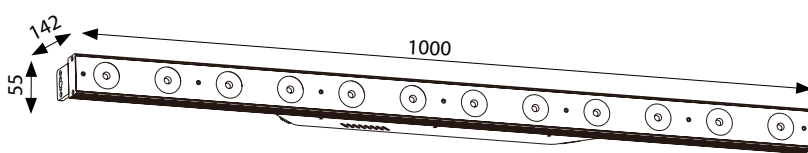



LED KITS

LED KIT 3 BATTERY



SG LEDKITHP3BAT - PRODUCT CODE

LIGHT SOURCE

- Kit 4 projectors 3x6W led RGBW Full Color
- LED lifespan: > 50.000h

OPTIC SYSTEM

- Beam Angle: 25°

COLOR SYSTEM

- Led Source 4 in 1 RGBW Full Color
- Infinite chromatic possibilities

EFFECTS

- Linear dimmer 0-100%
- Adjustable strobe effect
- Auto mode can be recalled by DMX

CONTROL AND PROGRAMMING

- 7 DMX configurations available: 4/5/6/9/10/16/20 channels
- Each projector can be controlled independently via DMX
- Protocol USITT DMX 512
- Master/Slave mode
- Sound mode with adjustable microphone sensitivity
- Automatic mode with 6 different programs selectable from the display or footswitch, with adjustment of the speed
- Color mode with 9 different pre-programmed color macros
- Wireless battery footswitch: Blackout, Sound, Auto, Freeze (included)

STRUCTURE AND CABINET

- Black metal housing
- Red LED display
- Mounting points: double adjustable brackets
- "light up"positioning
- XLR 3-poles DMX IN/OUT connection
- IP rating: IP20
- Stand max. H 2200
- Soft bag for bar for transport included

POWER SUPPLY

- Input Voltage: AC~100-240V, 50/60 Hz
- Switching power supply unit
- Max power: 80W @ 230VAC
- Internal Li – ion rechargeable battery
- Runtime battery: ~ 8 hrs (full ON)
- Charging cycle: ~ 5 hrs (led blackout when charging)
- Power supply cable included

WEIGHT AND DIMENSIONS:

- Bar net weight: 6,3 kg
- Stand net weight: 2,8 kg
- Bar Dimensions: 950x90x230 mm

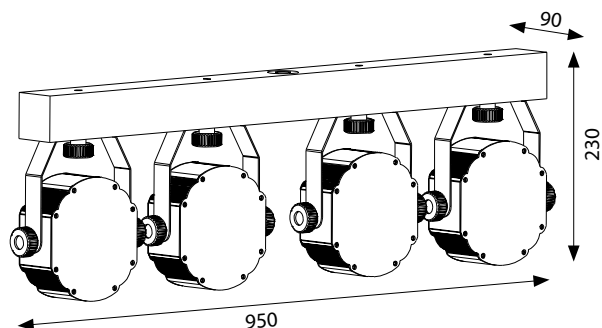

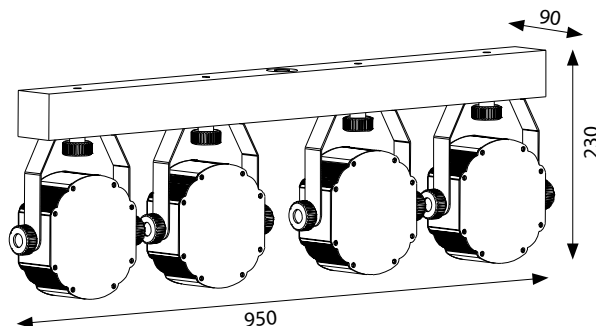

SG LEDKITHP3C - PRODUCT CODE

LIGHT SOURCE

- Kit 4 projectors 3x6W led RGBW Full Color
- LED lifespan: > 50.000h

OPTIC SYSTEM

- Beam Angle: 25°

COLOR SYSTEM

- Led Source 4 in 1 RGBW Full Color
- Infinite chromatic possibilities

EFFECTS

- Linear dimmer 0-100%
- Adjustable strobe effect
- Auto mode can be recalled by DMX

CONTROL AND PROGRAMMING

- 5 DMX configurations available: 4/6/10/16/18 channels
- Each projector can be controlled independently via DMX
- Protocol USITT DMX 512
- Master/Slave mode
- Sound mode with adjustable microphone sensitivity
- Automatic mode with 6 different programs selectable from the display or footswitch, with adjustment of the speed
- Color mode with 9 different pre-programmed color macros
- Footswitch control included: Blackout, Sound, Auto, Freeze

STRUCTURE AND CABINET

- Black metal housing
- Red LED display
- Mounting points: double adjustable brackets
- "light up"positioning
- XLR 3-poles DMX IN/OUT connection
- IP rating: IP20
- Stand max. H 2200
- Soft bag for bar for transport included

POWER SUPPLY

- Input Voltage: AC~100-240V, 50/60 Hz
- Switching power supply unit
- Max power: 80W @ 230VAC
- Power supply cable included

WEIGHT AND DIMENSIONS:

- Bar net weight: 5,8 kg
- Stand net weight: 2,8 kg
- Bar Dimensions: 950x90x230 mm

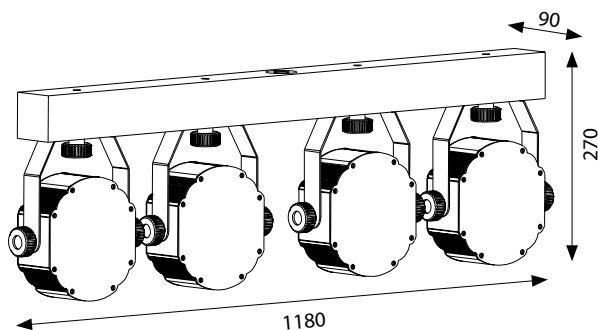

**SG LEDKITHP7BAT - PRODUCT CODE****LIGHT SOURCE**

- Kit 4 projectors 7x10W led RGBW Full Color
- LED lifespan: > 50.000h

OPTIC SYSTEM

- Beam Angle: 25°

COLOR SYSTEM

- Led Source 4 in 1 RGBW Full Color
- Infinite chromatic possibilities

EFFECTS

- Linear dimmer 0-100%
- Adjustable strobe effect
- Auto mode can be recalled by DMX

CONTROL AND PROGRAMMING

- 7 DMX configurations available: 4/5/6/9/10/16/20 channels
- Each projector can be controlled independently via DMX
- Protocol USITT DMX 512
- Master/Slave mode
- Sound mode with adjustable microphone sensitivity
- Automatic mode with 6 different programs selectable from the display or footswitch, with adjustment of the speed
- Color mode with 9 different pre-programmed color macros
- Wireless battery footswitch: Blackout, Sound, Auto, Freeze (included)

STRUCTURE AND CABINET

- Black metal housing
- Red LED display
- Mounting points: double adjustable brackets "light up"positioning
- XLR 3-poles DMX IN/OUT connection
- IP rating: IP20
- Stand max. H 2800
- Soft bag for bar for transport included

POWER SUPPLY

- Input Voltage: AC~100-240V, 50/60 Hz
- Switching power supply unit
- Max power: 300W @ 230VAC
- Internal Li-ion rechargeable battery
- Runtime battery: ~ 6 hrs (full ON)
- Charging cycle: ~ 5 hrs (led blackout when charging)
- Power supply cable included

WEIGHT AND DIMENSIONS:

- Bar net weight: 9,6 kg
- Stand net weight: 4,5 kg
- Bar Dimensions: 1180x90x270 mm



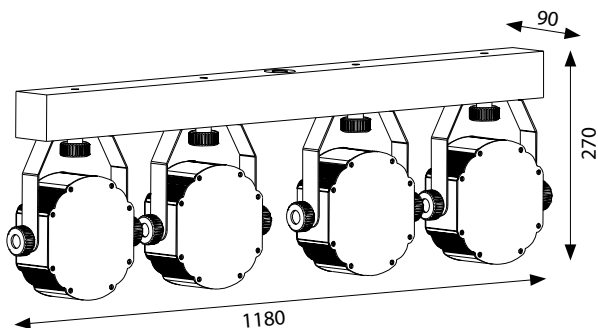
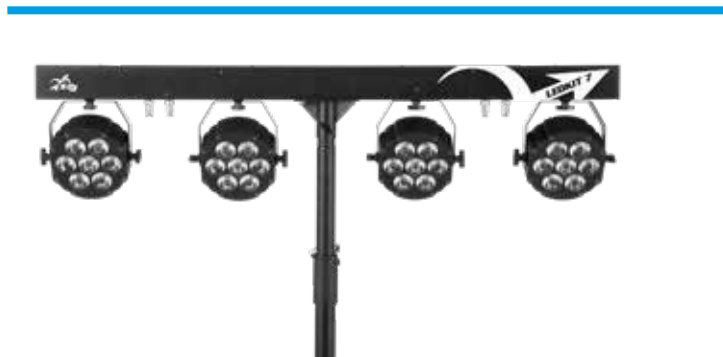

SG LEDKITHP7 - PRODUCT CODE

LIGHT SOURCE

- Kit 4 projectors 7x10W led RGBW Full Color
- LED lifespan: >50,000h
- LED refresh frequency: >400Hz flicker free

OPTIC SYSTEM

- Beam angle: 25°

COLOR SYSTEM

- LED source 4 in 1 RGBW Full Color
- Infinite chromatic possibilities and colour temperature control

EFFECTS

- Linear Dimmer 0-100%
- Electronic strobe: 1-20 flashes/s with adjustable speed
- 1 Auto mode can be recalled by DMX

CONTROL AND PROGRAMMING

- 5 DMX configurations available: 4/6/10/16/18 channels
- Each projector can be controlled independently
- Protocol USITT DMX 512
- Master / Slave mode
- Sound mode with adjustable mic sensitivity
- Automatic mode with 6 different programs selectable from the display or footswitch with independent adjustment of the speed
- Color mode with 9 different pre-programmed color macros + 1 adjustable macro
- Footswitch control included: Blackout, Sound, Auto, Freeze

STRUCTURE AND CABINET

- Metal housing, black color
- Red LED display
- Mounting points: double adjustable bracket
- "light up" positioning
- 3-poles XLR in/out connection
- IP rating: IP 20
- Stand max. H 2800 mm with bag for transport included
- Semi rigid bag for bar transport included

POWER SUPPLY

- Input Voltage: AC~100-240V 50/60Hz
- Switching power supply unit
- Max power: 300W @ 230VAC
- Power IN/OUT connection with VDE socket
- Power supply cable 1,5 mt included
- Max 4 pcs linkable @240V

WEIGHT AND DIMENSIONS:

- Bar Net weight: 8,5 kg
- Stand Net weight: 4,5 kg
- Bar Dimensions:: 1180x90x270 mm





CONTROLLERS

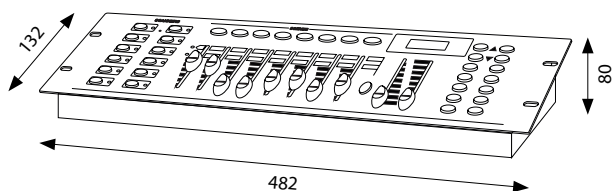

SG FASTER192N - PRODUCT CODE

TECHNICAL DATA

- DMX controller
- Max 12 projectors, 16 channel each
- Total 192 DMX channels
- 8 sliders for control (page A/B)
- 8 programmable scenes in 30 banks
- 6 chases
- Auto mode
- Sound mode (internal microphone)

POWER SUPPLY

- Input Voltage: DC 12V, 300 mA min
- External adapter included: AC~100-240V, 50/60Hz

WEIGHT AND DIMENSIONS:

- Net weight: 2,5 kg
- Dimensions: 482x132x80 mm





SG FASTER384 - PRODUCT CODE

TECHNICAL DATA

- DMX controller
- Max 12 projectors, 32 channels each
- Total 384 DMX channels
- 8 sliders for control (page A/B)
- 8 programmable scenes in 30 banks
- 6 chases
- Auto mode
- Sound mode (internal microphone)

POWER SUPPLY

- Input Voltage: DC 12V, 300 mA min
- External adapter included: AC~100-240V, 50/60Hz

WEIGHT AND DIMENSIONS

- Net weight: 2,5 kg
- Dimensions: 482x132x80 mm

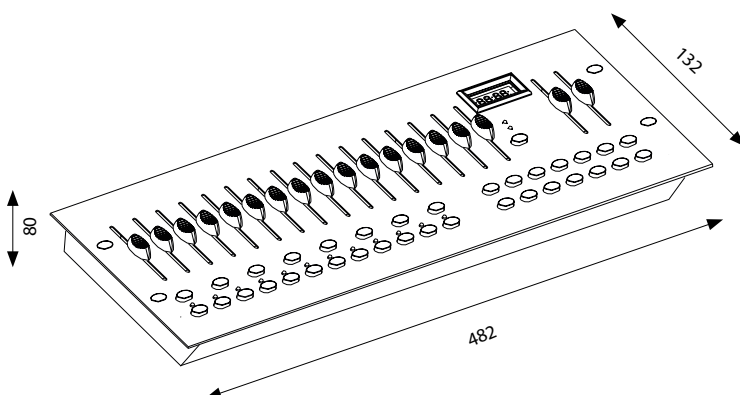

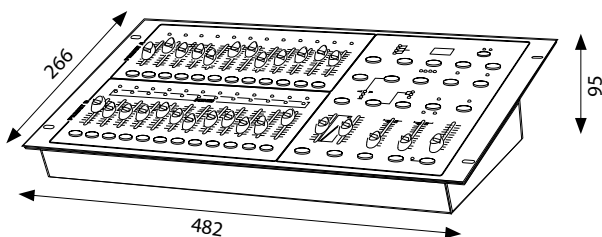

SG FASTER1224 - PRODUCT CODE

TECHNICAL DATA

- Controller for traditional projectors
- 24 DMX channels in total
- 24 control sliders
- 4 pages for 12 programs (up to 4.600 programmable steps)
- Fader setting and high speed execution for every single scene
- Possibility of edit a scene live or deferred
- Music mode (internal microphone)
- Compatible MIDI IN / OUT
- DMX polarity selector
- Sound-activated: Input audio

POWER SUPPLY

- Input Voltage: DC 12V, 500mA min
- External adapter included AC~100-240V, 50/60Hz

WEIGHT AND DIMENSION

- Net weight: 4,4 kg
- Dimensions: 482x266x95 mm



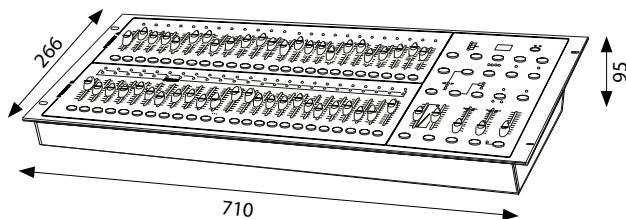
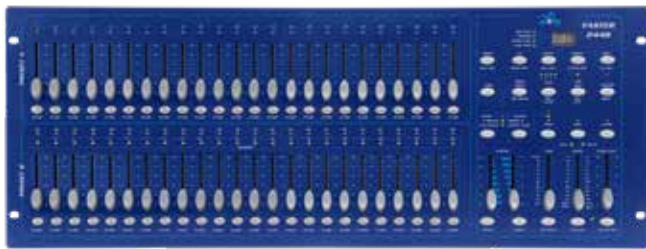

SG FASTER2448 - PRODUCT CODE

TECHNICAL DATA

- Controller for traditional projectors
- 48 DMX channels in total
- 48 control sliders
- 4 pages for 12 programs (up to 4.600 programmable steps)
- Fader setting and high speed execution for every single scene
- Possibility of edit a scene live or deferred
- Music mode (internal microphone)
- Compatible MIDI IN / OUT
- DMX polarity selector
- Sound-activated: Input audio

POWER SUPPLY

- Input Voltage: DC 12V, 500mA min
- External adapter included AC~100-240V, 50/60Hz

WEIGHT AND DIMENSION

- Net weight: 4,4 kg
- Dimensions: 482x266x95 mm





NEW

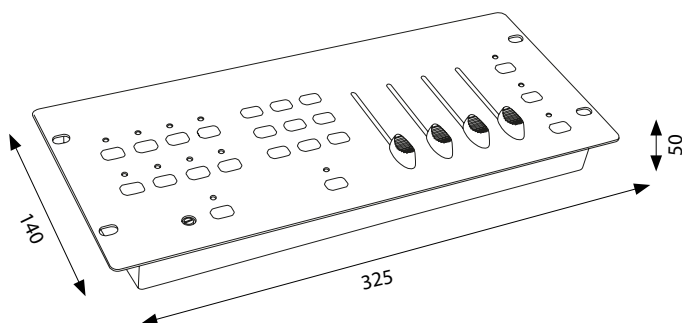

SG FASTER4 - PRODUCT CODE

TECHNICAL DATA

- DMX controller
- Max 4 projectors, 4 channel each
- Total 16 DMX channels
- 4 buttons for fixtures selection
- 4 faders for fixtures and effects control
- 4 buttons for Chases and Macro control
- RGB fade effects
- Automatic effects
- Color Macro effects
- 9 Chases color effects
- Strobe effect control
- Sound mode (internal microphone with adjustable sensitivity)

POWER SUPPLY

- Input Voltage: DC 9-12V, 500 mA min
- External adapter included: AC~100-240V, 50/60Hz

WEIGHT AND DIMENSIONS

- Net weight: 1,4 kg
- Dimensions 325x140x50 mm





NEW

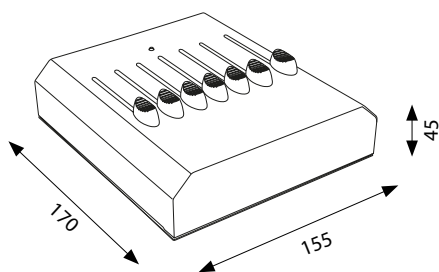

SG FASTER6 - PRODUCT CODE

TECHNICAL DATA

- DMX controller
- Total 6 DMX channels from CH1 to CH6
- 6 faders for fixtures control
- 9V battery NOT RECHARGEABLE (not included)

POWER SUPPLY

- Input Voltage: DC 9-12V, 500 mA min
- External adapter included: AC~100-240V, 50/60Hz
- 9V battery NOT RECHARGEABLE (not included)

WEIGHT AND DIMENSIONS

- Net weight: 0,7 kg
- Dimensions 155x170x45 mm





NEW



SG FASTERSP8 - PRODUCT CODE

TECHNICAL DATA

- 1 input - 8 output DMX512
- Opto-insulated Input and Outputs signals
- 1 DMX Input XLR 3-poles
- 1 DMX Input XLR 5-poles
- 8 DMX Outputs XLR 3-poles
- 1 DMX Thru XLR 3-poles for connection to another distributor
- 1 DMX Thru XLR 5-poles for connection to another distributor
- 1 Standard rack 19" unit

POWER SUPPLY

- AC~100-240V - 50/60Hz

WEIGHT AND DIMENSIONS

- Net weight: 2,0 kg
- Dimensions: 480x150x50 mm

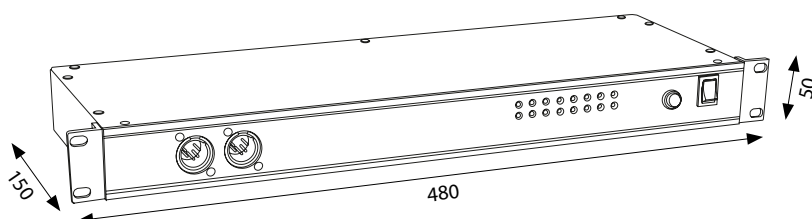



AMBIENT EFFECTS

CAUTION: HOT SURFACE:
DO NOT TOUCH.
KEEP AT LEAST 6 CM AWAY
FROM THE SPRAY
NOZZLE DURING
OPERATION.



SG H300 - PRODUCT CODE

EFFECTS

- Hazer effect

CONTROL AND PROGRAMMING

- 1 DMX channel configuration: 2 channels
- Fan's speed adjustable via software and via DMX
- Protocol USITT DMX 512
- Radio remote controller included
- Automatic safety shutdown circuit for pump prevention in case of finished liquid in the circuit
- Heating time: 2 mins
- Smoke output: 1000cuft
- Continue output
- Manual mode adjustable via display

STRUCTURE AND CABINET

- Metal black housing
- Red LED display
- Comfortable handle for transportation
- Led indicator for heating and ready to smoke
- High performance pump for optimal emission
- High speed axial fan
- External tank: 1,2 litres
- 3-poles XLR in/out connection
- IP rating: IP20
- For a correct operation we recommend to use Sagitter fluids

POWER SUPPLY

- Input Voltage: AC~230V 50Hz
- Max power: 650 W @ 230VAC
- IN power connection with VDE sockets
- Power supply cable 1,5 mt included

WEIGHT AND DIMENSIONS

- Net weight: 8 kg
- Dimensions: 235x355x200 mm

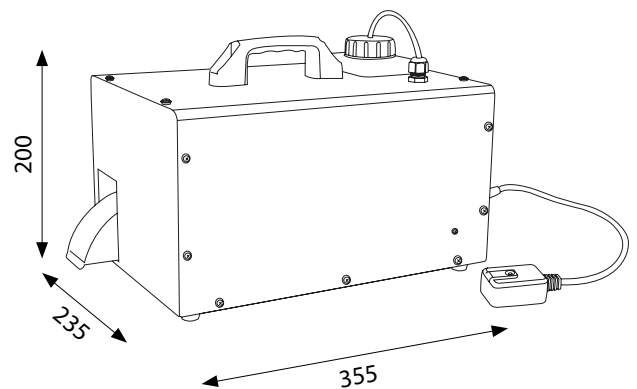



SG HYH900 - PRODUCT CODE

EFFECTS

- Hazer/smoke effect

CONTROL AND PROGRAMMING

- 1 DMX channels configuration: 2 channels
- Fan's speed adjustable via software and via DMX
- Protocol USITT DMX 512
- Heating time: 5 mins
- Continue output
- Manual mode adjustable via display

STRUCTURE AND CABINET

- Metal black housing
- LCD blue graphic display
- Comfortable handle for transportation
- High performance pump for optimal emission
- High speed axial fan
- External tank: 2 litres
- 3/5 poles XLR in/out connection
- IP rating: IP20
- For a correct operation we recommend to use Sagitter fluids

POWER SUPPLY

- Input Voltage: AC~230V 50Hz
- Max power: 900W @ 230VAC
- IN power connection with VDE sockets
- Power supply cable 1,5 mt included

WEIGHT AND DIMENSIONS

- Net weight: 10,4 kg
- Dimensions: 425x480x330 mm

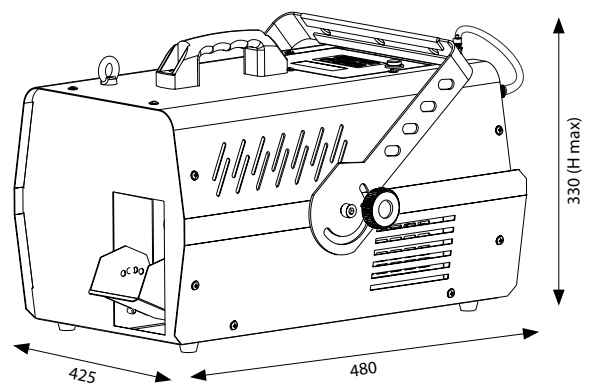



NEW

SG HS200 - PRODUCT CODE

EFFECTS

- Hazer effect

CONTROL AND PROGRAMMING

- 1 DMX channel configuration: 1 channel
- Protocol USITT DMX 512
- Radio remote controller included
- Heating time: 2 mins
- Smoke output: 800cuft
- Continue output
- Manual mode adjustable via display

STRUCTURE AND CABINET

- Metal black housing
- Red LED display
- Led indicator for heating and ready to smoke
- High performance pump for optimal emission
- High speed fan
- External tank: 2 litres
- 3-poles XLR in/out connection
- IP rating: IP20
- For best applications and correct function we recommend using Sagitter fluids

POWER SUPPLY

- Input Voltage: AC~230V, 50Hz
- Max Power: 480W @ 230VAC
- IN power connection with VDE sockets
- Power supply cable 1,5 mt included

WEIGHT AND DIMENSIONS

- Net weight: 4,7 kg
- Dimensions: 357x231x304 mm

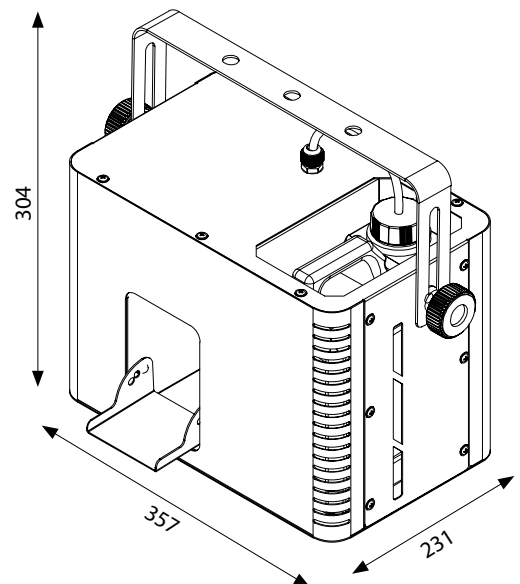



SG MIMETIKM - PRODUCT CODE

EFFECTS

- Smoke effect

CONTROL AND PROGRAMMING

- Radio remote controller included
- Wired remote controller with built-in timer
- Heating time: 5 min
- Continue output time: 20 sec.

STRUCTURE AND CABINET

- Metal housing
- Adjustable bracket
- Led indicator for heating and ready to smoke
- High performance pump for long-range
- External tank: 0,9 litres
- IP rating: IP20
- For a correct operation we recommend to use Sagitter fluids

POWER SUPPLY

- Input Voltage: AC~230V, 50 Hz
- Max power: 900W @ 230VAC

WEIGHT AND DIMENSIONS

- Net weight: 4,5 kg
- Dimensions: 235x240x140 mm

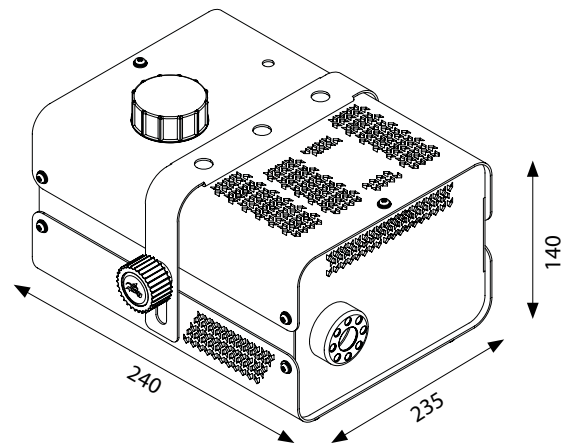

MIMETIK EXTRA LARGE



SG MIMETIKXL - PRODUCT CODE

EFFECTS

- Smoke effect

CONTROL AND PROGRAMMING

- Protocol USITT DMX 512
- Radio remote controller included
- Manual mode with specific button
- Heating time: 8 mins
- Continue output time: 10s

STRUCTURE AND CABINET

- Metal black/green housing
- Comfortable handle for transportation
- Red led indicator for heating and ready to smoke
- High performance pump for long-range
- External tank: 2,5 litres
- 3-poles XLR in/out connection
- IP rating: IP20
- For a correct operation we recommend to use Sagitter fluids

POWER SUPPLY

- Input Voltage: AC~230V 50Hz
- Max power: 1500W @ 230VAC
- IN power connection with VDE sockets
- Power supply cable 1,5 mt included

WEIGHT AND DIMENSIONS

- Net weight: 7,3 kg
- Dimensions: 190x440x305 mm

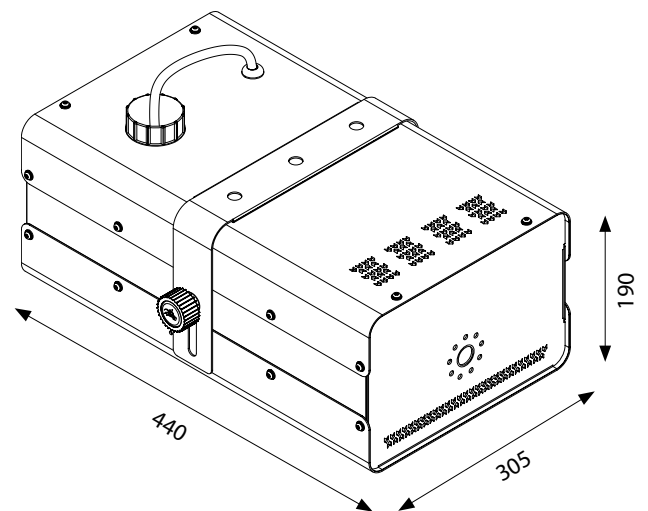



SG ARS1500FC - PRODUCT CODE

EFFECTS

- Smoke effect
- Geysier smoke effect 6 LED RGB full color

CONTROL AND PROGRAMMING

- 1 DMX configurations available: 7 channels
- Independent control smoke output and leds
- Protocol USITT DMX 512
- Radio remote controller included
- Auto mode with 7 pre-programmed colors
- Manual mode with specific button
- Automatic safety shutdown circuit for pump prevention in case of finished liquid in the circuit
- Heating time: 5 min
- Continue output time: 10 sec.

STRUCTURE AND CABINET

- Black metal housing
- Red LED display
- Comfortable handle for transportation
- Led indicator for heating and ready to smoke
- High performance pump for long-range
- Auxiliary pump for instant smoke stop
- Double working mode: horizontal and vertical
- External tank: 2,5 litres
- XLR 3/5-poles DMX IN/OUT connection
- IP rating: IP20
- For a correct operation we recommend to use Sagitter fluids

POWER SUPPLY

- Input Voltage: AC~230V, 50 Hz
- Max power: 1600W @ 230VAC
- Power supply cable 1mt included

WEIGHT AND DIMENSIONS

- Net weight: 8,5 kg
- Dimensions: 415x358x225 mm

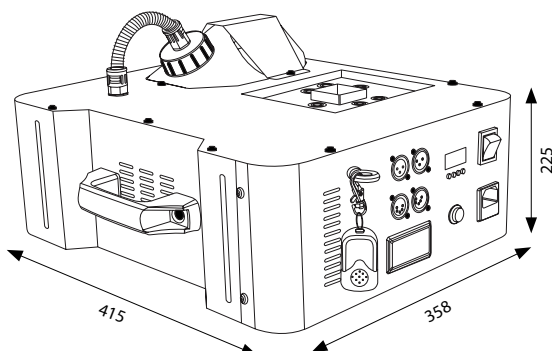



SG ARS900FC - PRODUCT CODE

EFFECTS

- Smoke effect
- Geyser smoke effect 6 LED RGB full color

CONTROL AND PROGRAMMING

- 1 DMX configurations available: 7 channels
- Independent control smoke output and leds
- Protocol USITT DMX 512
- Radio remote controller included
- Auto mode with 7 pre-programmed colors
- Manual mode with specific button
- Automatic safety shutdown circuit for pump prevention in case of finished liquid in the circuit
- Heating time: 5 min
- Continue output time: 10 sec.

STRUCTURE AND CABINET

- Black metal housing
- Red LED display
- Comfortable handle for transportation
- Led indicator for heating and ready to smoke
- High performance pump for long-range
- Auxiliary pump for instant smoke stop
- Double working mode: horizontal and vertical
- External tank: 2,5 litres
- XLR 3/5-poles DMX IN/OUT connection
- IP rating: IP20
- For a correct operation we recommend to use Sagitter fluids

POWER SUPPLY

- Input Voltage: AC~230V, 50 Hz
- Max power: 950wW @ 230VAC
- Power supply cable 1 mt included

WEIGHT AND DIMENSIONS

- Net weight: 7 kg
- Dimensions: 408x264x192 mm

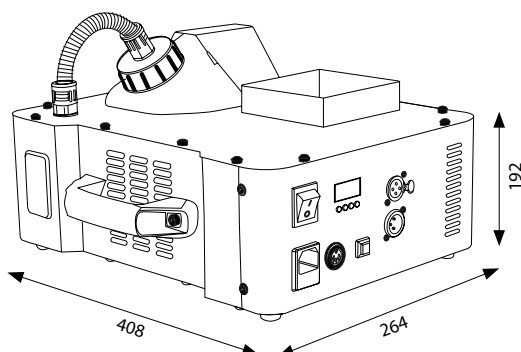



SG ARS900DJ - PRODUCT CODE

EFFECTS

- Smoke effect
- Geysier smoke effect 3 LED RGB full color

CONTROL AND PROGRAMMING

- Radio remote controller included
- Static color mode: 7 built-in colors
- Auto mode: 1 built-in color change program
- Manual mode with specific button
- Heating time: 8 min
- Continue output time: 10 sec.

STRUCTURE AND CABINET

- Black metal housing
- Comfortable handle for transportation
- Led indicator for heating and ready to smoke
- High performance pump for long-range
- Double working mode: horizontal and vertical
- External tank: 0,25 litres
- IP rating: IP20
- For a correct operation we recommend to use Sagitter fluids

POWER SUPPLY

- Input Voltage: AC~230V, 50 Hz
- Max power: 900W @ 230VAC
- Power supply cable 1mt included

WEIGHT AND DIMENSIONS

- Net weight: 3,5 kg
- Dimensions: 280x245x140 mm

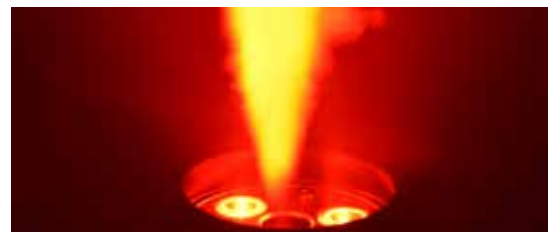
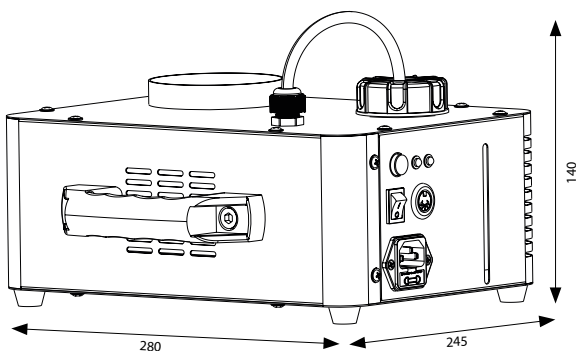



SAGITTER
genuine
ACCESSORIES

ACCESSORIES

PRO FLUIDS



LIGHT

Light version, suitable for small environments and 'occasional' users who want to get a nice smoke effect minimizing the expenses. This version can also be used for those who need a fast fading effect. 5 liters tank

- SG SMKFLD5L



MEDIUM

Version that provides an adequate coverage and durability for any kind of show, suitable for any location, i.e. live events, theaters and nightclubs. 5 liters tank

- SG SMKFLD5M



HIGH DENSITY

Condensed version which guarantees a long durability and an adequate coverage for a professional and covering smoke effect. 5 liters tank

- SG SMKFLD5D



HAZER

Condensed version which guarantees a long durability and an adequate coverage for a professional and covering smoke effect. 5 liters tank

- SG HZRFLD5

ACCESSORIES LAMPS

CODE	OSRAM	W	V	SOCKET	LIFETIME (H)	LM	PHILIPS	GE	NAED	ANSI	LIF
DOUBLEPLUG HALOGEN											
PLLP300M38	64662	300	230	GY9,5	2000	5000	6874P	M38-39785			M/38
PLLP500M40	64672	500	230	GY9,5	2000	8500	6877P	M40-39621			M/40
PLLP1000T19	64744	1000	230	GX9,5	750	20500	6996P	T19FWP-39657		FWP	T/19
PLLP200016	64788	2000	230	GY16	400	52000	6994P				CP/72
PLLP575HTC	93728	575	230	G9,5	300	14900		HPL575-37128	54618		
PLLP750HTC	93729	750	230	G9,5	300	19750		HPL750-37824			
PAR 36											
PLLPP36V		30	6	screw	100	55000		4515-24673			
PLLPDWE		650	120	screw	100	24000		DWE-41667			
PAR 56											
PLLPP56V		300	230	GX16d	2000	10000			300PAR56\NSP		
PAR 64											
PLLPP645V		500	230	GX16d	300			CP87-30283			CP/87
PLLPP64A		1000	230	GX16d	300	320000	PAR64NSP	CP60EXC-19909	56332	EXC	CP/60
PLLPP64B		1000	230	GX16d	300	270000	PAR64SP	CP61EXD-19911	56233	EXD	CP/61
PLLPP64C		1000	230	GX16d	300	125000	PAR64FL	CP62EXE-19913	56234	EXE	CP/62
PLLP6428V		250	28	screw	25			4552-VNSP			

CODE	OSRAM	W	V	SOCKET	LIFETIME (H)	LM	PHILIPS	GE	NAED	ANSI	LIF
------	-------	---	---	--------	--------------	----	---------	----	------	------	-----

Made in China

DISCHARGE HMI SERIES

PLLPHMI575CN	HMI 575W/GS	575	VG	SFc 10-4	nd	nd	MSI 575W	CSR575/DE			
--------------	-------------	-----	----	----------	----	----	----------	-----------	--	--	--

DISCHARGE HSD SERIES

PLLPHSD250CN	HSD 250	250	VG	GY9,5	nd	nd	MSD 250	CSD 250			
--------------	---------	-----	----	-------	----	----	---------	---------	--	--	--

DISCHARGE HSR/MSR SERIES

PLLPHSR575CN	HSR 575/60	575	VG	GX9,5	nd	nd	MSR 575	CSR 575			
--------------	------------	-----	----	-------	----	----	---------	---------	--	--	--

ACCESSORIES LAMPS

CODE	OSRAM	W	V	SOCKET	LIFETIME (H)	LM	PHILIPS	GE	NAED	ANSI	LIF
WOOD TUBE											
PLLP18W		18	VG	G13	9000		TLD18W/08	F20T12/BLB			
PLLP36W		36	VG	G13	20000		TLD36W/08	F40T12/BLB			
STROBE HIGH POWER											
PLLPXOP15N		1000	VS	CAP15,8,14,7cab	250	350000	XOP15-OF				
DISCHARGE HMI SERIES											
PLLPHMI575GS	HMI 575W/GS	575	VG	SFc 10-4	1000	49000	MSI 575W	CSR575/DE			
PLLPHMI1200GS	HMI 1200W/GS	1200	VG	SFc 15,5-6	1000	110000	MSI 1200W	CSR1200/DE			
DISCHARGE HSD SERIES											
PLLPHSD250	HSD 250	250	VG	GY9,5	2000	17000	MSD 250				
DISCHARGE HSR/MSR SERIES											
PLLPHSR575	HSR 575/60	575	VG	GX9,5	1000	49000					
PLLPMSR1200SA		1200	VG	GY22	750	96000	MSR 1200SA	CSR1200SA			
DISCHARGE REFLECTOR SERIES											
SG LTUHP190W		190/160		2 terminations			UHP 160/190W 0.9 E20.9				
SG LTUHP200W		200/170		2 terminations			TOP UHP 200/170W				
SG LTVIP280W	P-VIP 280/1.0 E20.6	280		2 terminations							
SG PLHRI230	SIRIUS HRI 230W	230		2 terminations	2500						
SG PLHRI280	SIRIUS HRI 280W	280		2 terminations	2000						
SG PLHRI132	SIRIUS HRI 132W	132		2 terminations	6000						
SG PLHRI100	SIRIUS HRI 100W	100		2 terminations	6000						
DISCHARGE FASTFIT SERIES											
SG PL300LK		300		PGJX28	750	23000	MSR Gold 300/2 Mini FastFit 1CT/4				
SG PL700LK		700		PGJX50	750	50000	MSR Gold 700/2 FastFit 1CT/8				
SG PL700LK28		700		PGJX28	750	47000	MSR Gold 700/2 Mini FastFit 1CT/4				

ACCESSORIES

SAGITTER DMX CABLES



DMX CABLE 3 POLES

Professional DMX cable made in Italy with Neutrik connections series XX XLR 3 poles. Composition: 1x NC3FXXB 1x SG DMXBBL 1x NC3MXXB. Cable color: Blue

- SG DMX3LU01 - 1 mt.
- SG DMX3LU02 - 2 mt.
- SG DMX3LU03 - 3 mt.
- SG DMX3LU05 - 5 mt.
- SG DMX3LU10 - 10 mt.



DMX CABLE 5 POLES

Professional DMX cable made in Italy with Neutrik connections series XX XLR 5 poles. Composition: 1x NC5FXXB 1x SG DMXBBL 1x NC5MXXB. Cable color: Blue

- SG DMX5LU01 - 1 mt.
- SG DMX5LU02 - 2 mt.
- SG DMX5LU03 - 3 mt.
- SG DMX5LU05 - 5 mt.
- SG DMX5LU10 - 10 mt.



SDJ DMX CABLES

DMX CABLE 3 POLES

Professional DMX 512 cable with YONGSCHENG connectors XLR 3 poles. Cable color: Black

- SG DMX3CLU02 - 2 mt.
- SG DMX3CLU03 - 3 mt.
- SG DMX3CLU05 - 5 mt.
- SG DMX3CLU010 - 10 mt.



DMX CABLE 5 POLES

Professional DMX 512 cable with YONGSCHENG connectors XLR 5 poles. Cable color: Black

- SG DMX5CLU02 - 2 mt.
- SG DMX5CLU03 - 3 mt.
- SG DMX5CLU05 - 5 mt.
- SG DMX5CLU010 - 10 mt.



ACCESSORIES

CABLES

POWERCON EXTENSION CABLES

SDC775LU015	Powercon cable 3x2,5mm 1,5 mt
SDC775LU025	Powercon cable 3x2,5mm 2,5 mt
SDC775LU05	Powercon cable 3x2,5mm 5 mt
SDC775LU10	Powercon cable 3x2,5mm 10 mt
SM300LU5	Power cable mounth EC female socket - SCHIUKO 3x1mm 5mt
SM300LU10	Power cable mounth EC female socket - SCHIUKO 3x1mm 10mt
SM300LU15	Power cable mounth EC female socket - SCHIUKO 3x1mm 15mt

IP DMX EXTENSION CABLES FOR IP LED SERIES

SG IPCDLU3	DMX cable IP 65 3 mt
SG IPCDLU05	DMX cable IP 65 5 mt
SG IPCDLU10	DMX cable IP 65 10 mt

IP POWER EXTENSION CABLES FOR IP LED SERIES

SG IPCPLU3	Power cable IP 65 3 mt
SG IPCPLU5	Power cable IP 65 5 mt
SG IPCPLU10	Power cable IP 65 10 mt

IP DMX/POWER EXTENSION CABLES FOR MICRO BAR LED SERIES

SG IPCPDLU3	Power/DMX cable IP 65 3 mt for IPLED MICRO BAR RGB
SG IPCPDLU5	Power/DMX cable IP 65 5 mt for IPLED MICRO BAR RGB
SG IPCPDLU10	Power/DMX cable IP 65 10 mt for IPLED MICRO BAR RGB

ACCESSORIES

CABLECROSS

SG CABLECRS2 - PRODUCT CODE

TECHNICAL DATA

- 2 channels cable cross
- Conduits for cable routing up to 30mm section
- Base made of thermoplastic polyurethane
- Closing panel: made of yellow PVC
- Capacity: ≤ 3000 kg (uniformly distributed load)
- Conduits measures: 1000x30x30 mm
- Platform measures: 1000x45x250 mm
- Weight: 4.0 kg

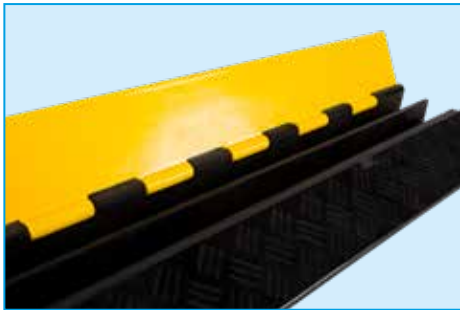

SG CABLECRS5 - PRODUCT CODE

TECHNICAL DATA

- 5 channels cable cross
- Conduits for cable routing up to 35mm section
- Base made of thermoplastic polyurethane
- Closing panel: made of yellow PVC
- Capacity: ≤ 4500 kg (uniformly distributed load)
- Conduits measures: 4x(1000x35x40 mm) / 1x(1000x40x40 mm)
- Platform measures: 1000x500x55 mm
- Weight: 9.0 kg

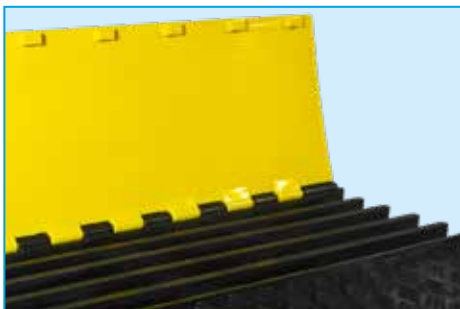

ACCESSORIES

CABLECROSS

SG CABLECVR1S - PRODUCT CODE

TECHNICAL DATA

- 1 channels cable cross
- Conduits for cable routing up to 30mm section
- Cable cross made of thermoplastic polyurethane
- Capacity: ≤ 1000 kg (uniformly distributed load)
- Conduits measures: 1000x40x13 mm
- Platform measures: 1000x135x25 mm
- Weight: 2.0 kg



SG CABLECVR1XS - PRODUCT CODE

TECHNICAL DATA

- 1 channels cable cross
- Conduits for cable routing up to 6.4mm section
- Cable cross made of PVC and NBR
- Capacity: ≤ 200 kg (uniformly distributed load) per 9 mt.
- Conduits measures: 9000x19x9.5 mm
- Platform measures: 9000x77x16 mm
- Weight: 7.0 kg



ACCESSORIES

CLAMPS



PLH290BK

Black Simple extruded aluminium coupler



PLH295BK

Black Simple extruded aluminium coupler



PLH10NBK

Black Galvanized steel hook clamp



PLH350BK

Black Simple extruded aluminium coupler

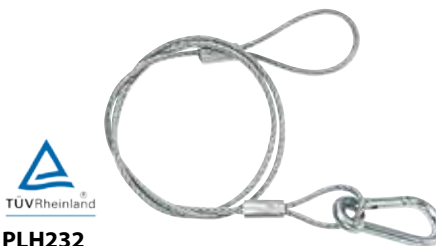

**PLH232
PLH248**

Security PVC covered galvanized stainless steel cable with snap hook.



PLH10N

Galvanized steel hook clamp



PLH270

Simple extruded aluminium coupler



PLH290

Simple extruded aluminium coupler



PLH295

Simple extruded aluminium coupler



PLH300

Simple extruded aluminium coupler



PLH340

Accoppiatore in robusto alluminio 6061 T6 estruso.



PLH420

Staffa zincata regolabile per truss con doppio accoppiatore singolo.

PLATFORMS MODULA SERIES



PLATFORMS MODULA SERIES

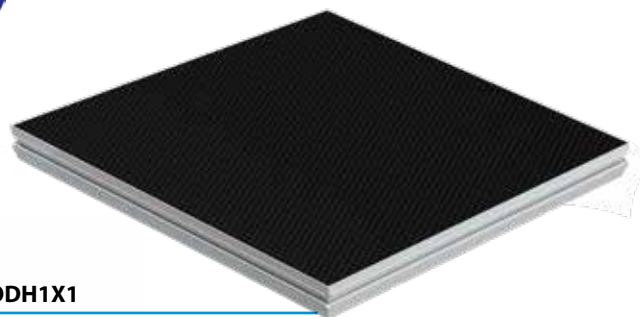

MODH1X1



MODH2X1



MODH2X1

Stage platform structure made by extruded aluminum and weather resistant plywood with slip coating HEXA surface. Supplied without legs. Dimension: 2000 x 1000 x 90 mm (WxDxH).

MODW2X1

Stage platform structure with same features of MODH2X1 but with natural wood surface. Supplied without legs. Dimension: 2000 x 1000 x 90 mm (WxDxH).

MODP2X1

Stage platform structure with same features of MODH2X1 but with transparent plexiglass surface. Supplied without legs. Dimension: 2000 x 1000 x 90 mm (WxDxH).

MODH1X1

Stage platform structure made by extruded aluminum and weather resistant plywood with slip coating HEXA surface. Supplied without legs. Dimension: 1000 x 1000 x 90 mm (WxDxH).

MODW1X1

Stage platform structure with same features of MODH2X1 but with natural wood surface. Supplied without legs. Dimension: 1000 x 1000 x 90 mm (WxDxH).

MODP1X1

Stage platform structure with same features of MODH2X1 but with transparent plexiglass surface. Supplied without legs. Dimension: 1000 x 1000 x 90 mm (WxDxH).

TECH INFO

MODH2X1	32 Kg (70,55 lbs)
MODW2X1	32 Kg (70,55 lbs)
MODP2X1	45 Kg (99,20 lbs)
MODH1X1	17,5 Kg (38,58 lbs)
MODW1X1	17,5 Kg (38,58 lbs)
MODP1X1	22 Kg (48,50 lbs)

• Loading Weight 750 Kg/m² - according to DIN 15921

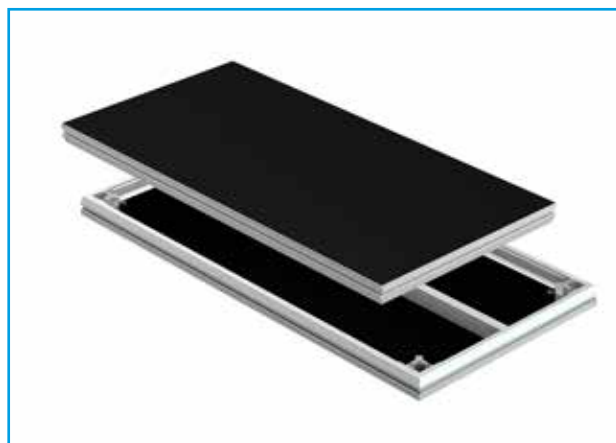

MODW2X1

PLATFORMS MODULA SERIES

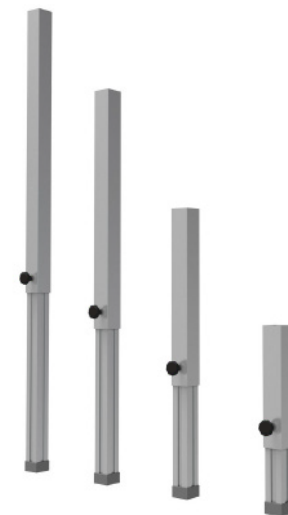
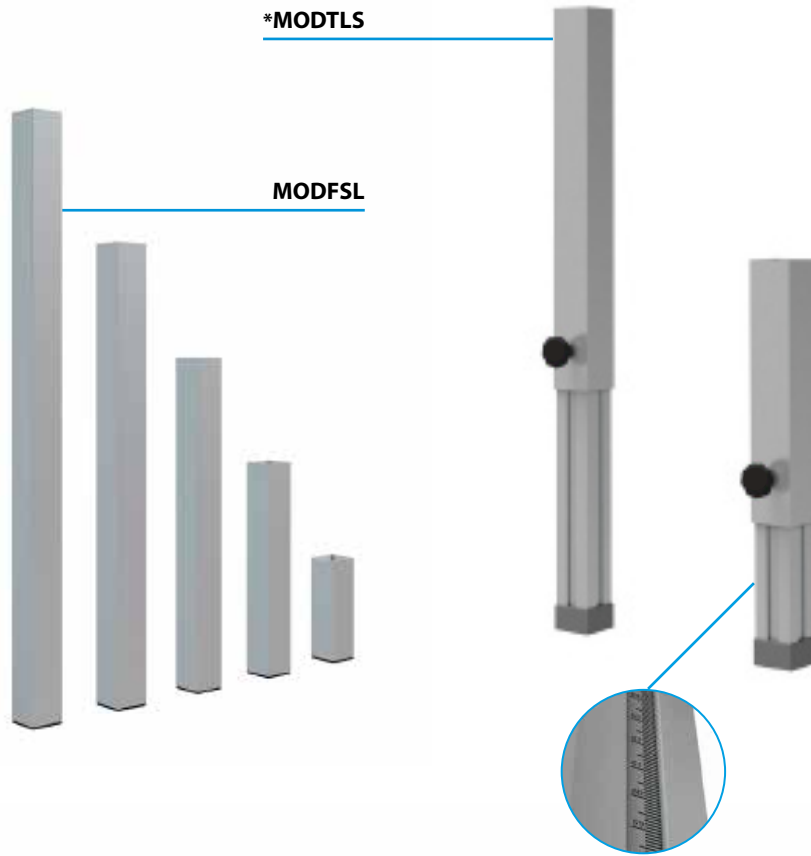

MODTSL SERIES

Single telescopic leg, made of square extruded aluminum, available in two different heights. Refer to the technical table chart.

* CODE	HEIGHT
MODTSL40	40 – 60 cm
MODTSL60	60 – 100 cm

MODFSL SERIES

Single fixed leg, made of square extruded aluminum, available in different heights. Refer to the technical table chart.

CODE	HEIGHT
MODFSL20	20 cm
MODFSL40	40 cm
MODFSL60	60 cm
MODFSL80	80 cm
MODFSL100	100 cm

PLATFORMS MODULA SERIES



MOD01DDC



MOD04LL2



MOD04LL4

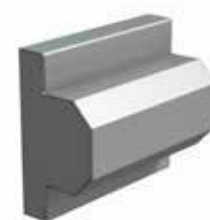

MOD02LEV

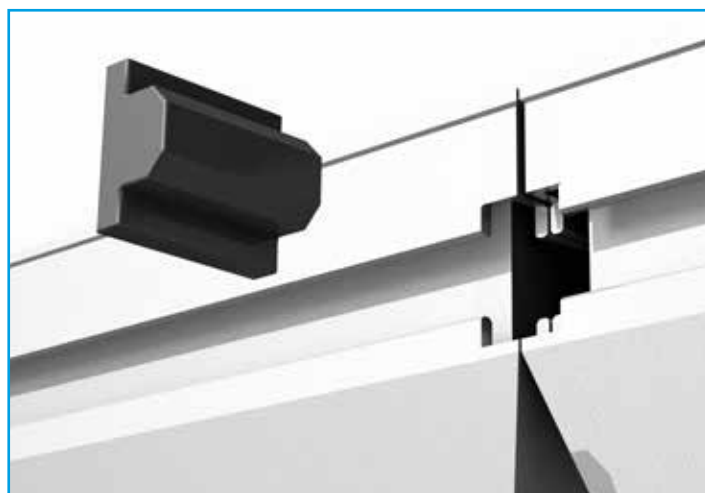

MOD01DDC

Connection clamp to connect two adjacent platforms. It is recommended to use two clamps on the 2 meter side and one clamp for 1 meter side.

MOD04LL2

Steel clamp to connect two adjacent legs.

MOD04LL4

Steel clamp to connect four adjacent legs.

MOD02LEV

Aluminum insert to keep two adjacent platforms at the same level.

PLATFORMS MODULA SERIES



MODULAR STAIR EXAMPLE



MODSTRHR



MODSTR20



MODSTR40



MODSTR60



MODSTR80

MODULAR STAIR EXAMPLE



MODSTR SERIES

Steel step for modular stair, available in different heights. The steps can be used individually or together for different needs. Supplied with universal connection system to the platform.

CODE	HEIGHT
MODSTR20	20 cm
MODSTR40	40 cm
MODSTR60	60 cm
MODSTR80	80 cm

MODSTRHR

Steel handrail for modular stair, to be used with two adjacent steps of different heights.

PLATFORMS MODULA SERIES



MODSTA60



MODSTA40

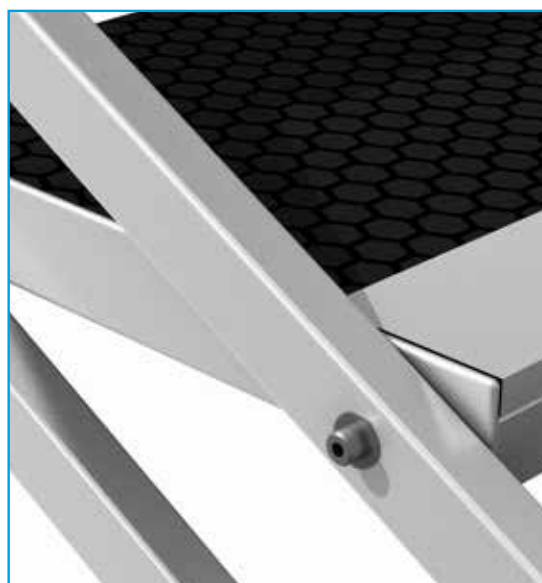

ADJUSTABLE STAIR EXAMPLE

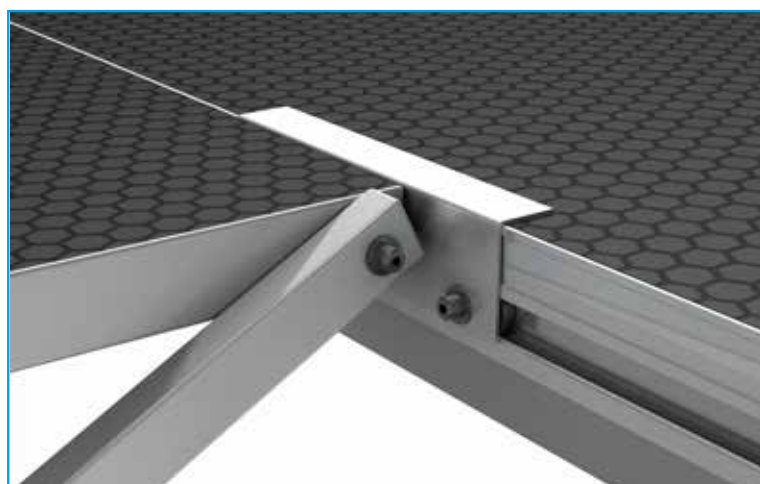

MODSTA40

Two steps stair, with adjustable height from 40 to 60 cm. For this model does not use the handrail.

MODSTA60

Four steps stair, with adjustable height from 60 to 100 cm.

MODSTAHR

Right side adjustable stair handrail, o be used with MODSTA60 only.

MODSTAHL

Right side adjustable stair handrail, o be used with MODSTA60 only.

PLATFORMS MODULA SERIES

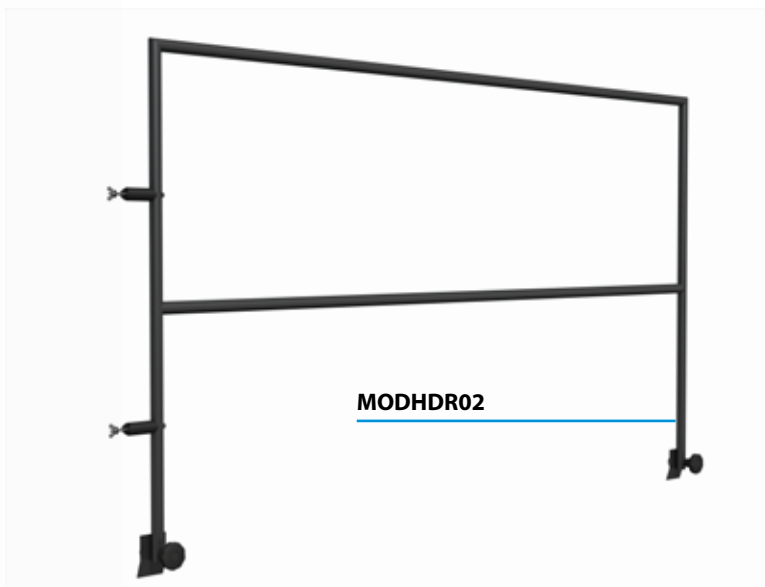
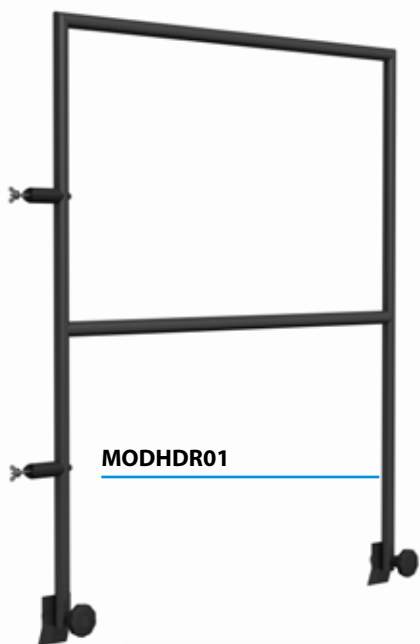

MODHDR02

Two meter length galvanized steel handrail, for standard use on stage with no public access.

MODHDR01

One meter length galvanized steel handrail, for standard use on stage with no public access.

MODHDC1

Angular handrail connection.

MODHDC2

Straight handrail connection.



ACCESSORIES

FLIGHTCASES

SG CASESAGOLED	Flightcase with wheels for 4 SAGOLED
SG CASECLUB	Flightcase with wheels for 4 CLUB SERIES SPOT BEAM
SG CASEPIXIS	Flightcase with wheels for 6 PIXIS/SW
SG CASELTBEAM	Flightcase with wheels for 2 LITE BEAM
SG CASEACLBAR	Flightcase with wheels for 4 ACL LED BAR
SG CASESAGOLEDM	Flightcase for 4 SAGOLED MINI
SG CASESCLWASH	Flightcase with wheels for 4 CLUB WASH
SG CASEHTZ	Flightcase with wheels for 6 HTZ LED
SG CASEBATI4DLH	Flightcase with wheels for 8 BATI 4DLH with battery charge system
SG CASEQUARTZ100	Flightcase with wheels for 4 QUARTZ100
SG CASEQUARTZ300	Flightcase with wheels for 2 QUARTZ300
SG CASEQUARTZ300X4	Flightcase with wheels for 4 QUARTZ300
SG CASECLDOTZ	Flightcase with wheels for 4 CLUB DOTZ
SG CASEHALOFM	Flightcase for 4 HALOFWWM60
SG CASEHALOPR	Flightcase with wheels for 4 HALOPFWW 200
SG CASEQUIVER	Flightcase for QUIVER
SG CASEQUIVER1X	Flightcase for QUIVER + 1 QUIVERX
SG CASEQUIVER2X	Flightcase for QUIVER + 2 QUIVERX
SG CASESLIMBAR16DL	Flightcase with wheels for 4 SLIMBAR16DL
SG CASESLIMBAR8DL	Flightcase with wheels for 6 SLIMBAR8DL
SG CASEPIXISWL	Flightcase with wheels for 8 PIXISWL
SG CASEHALOFR	Flightcase with wheels for 4 HALOFWW 100/200
SG CASELTSPOT	Flightcase with wheels for 2 LITE SPOT
SG CASESTUDIOP	Flightcase with wheels for 4 STUDIO PANEL LED
SG CASESOLPAR60	Flightcase with wheels for 6 SOLPAR 60
SG CASESOLPAR150	Flightcase with wheels for 4 SOLPAR 150
SG CASEAQUPAR	Flightcase with wheels for 6 AQUPAR
SG CASEQUARIUX	Flightcase with wheels for 6 QUARIUX
SG CASESAGOLED300	Flightcase with wheels for 4 SAGOLED 300
SG CASEBLAZERC	Flightcase with wheels for 4 BLAZER 1500 C
SG CASEIPLD32C	Flightcase with wheels for 4 IPLD 32C DL
SG CASEIPLD BARBAT	Flightcase with wheels for 4 IPLD BAR 8 BATTERY
SG CASEJNRPRO	Flightcase with wheels for 6 JUNIOR PROFILE
SG CASEHALOPM	Flightcase with wheels for 4 HALO PROFILE ZOOM 60
SG CASEBLOK2	Flightcase with wheels for 4 BLOK 2TW
SG CASECLBEAM7R	Flightcase with wheels for 2 CLUB BEAM 7R
SG CASESLIMPARBAT	Flightcase with wheels for 6 SLIMPAR 6 BATTERY
SG CASESLIMBARBAT	Flightcase with wheels for 5 SLIMBAR 8 BATTERY

ACCESSORIES

CODE	DESCRIPTION	COMPATIBLE MODEL
SG SOLPARC60BN	Directional barndoor	SG SOLPARC60Z
SG SOLPARC150BN	Directional barndoor	SG SOLPARC150Z
SG LENS19C	Optics 19°	SG SAGOLEDW - SG SAGOLEDWW
SG LENS26C	Optics 26°	SG SAGOLEDW - SG SAGOLEDWW
SG LENS36C	Optics 36°	SG SAGOLEDW - SG SAGOLEDWW
SG LENS50C	Optics 50°	SG SAGOLEDW - SG SAGOLEDWW
SG IRIS	Iris Accessory	SG SAGOLEDW - SG SAGOLEDWW
SG LENS19M	Optics 19°	SG SAGOLEDWWM - SG SAGOLEDWWM
SG LENS26M	Optics 26°	SG SAGOLEDWWM - SG SAGOLEDWWM
SG LENS36M	Optics 36°	SG SAGOLEDWWM - SG SAGOLEDWWM
SG LENS50M	Optics 50°	SG SAGOLEDWWM - SG SAGOLEDWWM
SG IRISM	Iris Accessory	SG SAGOLEDWWM - SG SAGOLEDWWM
SG LENS19	Optics 19°	SG SAGOLEDWW300 - SG SAGOLEDWW300
SG LENS26	Optics 26°	SG SAGOLEDWW300 - SG SAGOLEDWW300
SG LENS36	Optics 36°	SG SAGOLEDWW300 - SG SAGOLEDWW300
SG LENS50	Optics 50°	SG SAGOLEDWW300 - SG SAGOLEDWW300
SG IRIS	Iris Accessory	SG SAGOLEDWW300 - SG SAGOLEDWW300
SG IRISM	Iris Accessory	SG HALOPWWM60 - SG HALOPWWM60
SG IRIS	Iris Accessory	SG HALOPWW2045 - SG HALOPWW1528
SG IRISJ	Iris Accessory	SG JNRPROWW - SG JNRPROCW - SG JNRPRORGW
SG LENS14J	Optics 14°	SG JNRPROWW - SG JNRPROCW - SG JNRPRORGW
SG LENS19J	Optics 19°	SG JNRPROWW - SG JNRPROCW - SG JNRPRORGW
SG LENS26J	Optics 26°	SG JNRPROWW - SG JNRPROCW - SG JNRPRORGW
SG LENS36J	Optics 36°	SG JNRPROWW - SG JNRPROCW - SG JNRPRORGW

ALPHABETICAL INDEX

CODE	PAG
MOD01DDC	126
MOD01DDC	126
MOD02LEV	126
MOD02LEV	126
MOD04LL2	126
MOD04LL2	126
MOD04LL4	126
MOD04LL4	126
MODFSL	125
MODFSL20	125
MODFSL40	125
MODFSL60	125
MODFSL80	125
MODFSL100	125
MODH1X1	124
MODH1X1	124
MODH1X1	124
MODH2X1	124
MODH2X1	124
MODH2X1	124
MODH2X1	124
MODHDR01	129
MODHDR01	129
MODHDR02	129
MODHDR02	129
MODHDRC1	129
MODHDRC2	129
MODHDRC2	129
MODP1X1	124
MODP1X1	124
MODP2X1	124
MODP2X1	124
MODSTA40	128
MODSTA60	128
MODSTahr	128
MODSTahrL	128
MODSTR20	127
MODSTR20	127
MODSTR40	127
MODSTR40	127
MODSTR60	127
MODSTR60	127
MODSTR80	127
MODSTR80	127
MODSTRHR	127
MODSTRHR	127
*MODTLS	125
MODTSL40	125

CODE	PAG
MODTSL60	125
MODW1X1	124
MODW1X1	124
MODW2X1	124
MODW2X1	124
MODW2X1	124
PLH10N	122
PLH10NBK	122
PLH232	122
PLH248	122
PLH270	122
PLH290	122
PLH290BK	122
PLH295	122
PLH295BK	122
PLH300	122
PLH340	122
PLH350BK	122
PLH420	122
PLL18W	117
PLL36W	117
PLL300M38	116
PLL500M40	116
PLL575HTC	116
PLL750HTC	116
PLL1000T19	116
PLL6428V	116
PLL200016	116
PLLPDWE	116
PLLPHMI575CN	116
PLLPHMI575GS	117
PLLPHMI1200GS	117
PLLPHSD250	117
PLLPHSD250CN	116
PLLPHSR575	117
PLLPHSR575CN	116
PLLPMSR1200SA	117
PLLP36V	116
PLLP56V	116
PLLP64A	116
PLLP64B	116
PLLP64C	116
PLLP645V	116
PLLPXOP15N	117
QUIVER	50
QUIVER X	50
SDC775LU05	119

CODE	PAG
SDC775LU10	119
SDC775LU015	119
SDC775LU025	119
SG ACLBAR5	9
SG ACLBAR10	8
SG ACLPAR1	10
SG ACLPARBAG	11
SG ACLPARBATBKC	11
SG ACLPARBATWHC	11
SG ACLPARCHR	11
SG AIRBOXIP	47
SG AIRBOX	47
SG AQUPAR7	38
SG AQUPAR12	39
SG AQUPAR18	40
SG AQUPARBN	39
SG AQUPARBN	40
SG ARS900DJ	113
SG ARS900FC	112
SG ARS1500FC	111
SG BAGBATI4DLH	81
SG BATI4DLHKIT	81
SG BATI4DLH	81
SG BATI4TX	81
SG BLAZER1500C	35
SG BLOK2TWH	36
SG BLOK2TW	36
SG CABLECRS2	120
SG CABLECRS5	120
SG CABLECVR1S	121
SG CABLECVR1XS	121
SG CASEACLBAR	130
SG CASEACLBAR	9
SG CASEACLBAR	8
SG CASEAQUPAR	130
SG CASEAQUPAR	38
SG CASEAQUPAR	39
SG CASEAQUPAR	40
SG CASEBATI4DLH	130
SG CASEBATI4DLH	81
SG CASEBLAZERC	130
SG CASEBLAZERC	35
SG CASEBLOK2	130
SG CASEBLOK2	130
SG CASEBLOK2	36
SG CASECLBEAM7R	130
SG CASECLBEAM7R	130

CODE	PAG
SG CASECLBEAM7R	64
SG CASECLDOTZ	130
SG CASECLUB	130
SG CASECLUB	62
SG CASECLUB	61
SG CASEHALOFM	130
SG CASEHALOFM	29
SG CASEHALOFR	130
SG CASEHALOFR	27
SG CASEHALOFR	28
SG CASEHALOPM	130
SG CASEHALOPM	130
SG CASEHALOPM	32
SG CASEHALOPR	130
SG CASEHALOPR	30
SG CASEHALOPR	31
SG CASEHTZ	130
SG CASEHTZ	77
SG CASEHTZCOB	79
SG CASEHTZCOB	78
SG CASEIPLED32C	130
SG CASEIPLED32C	130
SG CASEIPLED32C	14
SG CASEIPLEDBARBAT	130
SG CASEIPLEDBARBAT	130
SG CASEIPLEDBARBAT	20
SG CASEJNRPRO	130
SG CASEJNRPRO	130
SG CASEJNRPRO	26
SG CASELTBEAM	130
SG CASELTSPOT	130
SG CASEPIXI5	130
SG CASEPIXI5	89
SG CASEPIXI5	90
SG CASEPIXI5WL	130
SG CASEPIXI5WL	91
SG CASEQUARIUX	130
SG CASEQUARIUX	13
SG CASEQUARTZ100	130
SG CASEQUARTZ100	6
SG CASEQUARTZ300	130
SG CASEQUARTZ300	5
SG CASEQUARTZ300X4	130
SG CASEQUARTZ300X4	5
SG CASEQUIVER	130
SG CASEQUIVER1X	130
SG CASEQUIVER1X	49

CODE	PAG
SG CASEQUIVER2X	130
SG CASEQUIVER2X	49
SG CASEQUIVER	49
SG CASESAGOLED	130
SG CASESAGOLED300	130
SG CASESAGOLED300	23
SG CASESAGOLED300	22
SG CASESAGOLED	24
SG CASESAGOLEDM	130
SG CASESAGOLEDM	25
SG CASESCLWASH	130
SG CASESCLWASH	63
SG CASESLIMBAR8DL	130
SG CASESLIMBAR8DL	84
SG CASESLIMBAR16DL	130
SG CASESLIMBAR16DL	83
SG CASESLIMBAR16DL	85
SG CASESLIMBARBAT	130
SG CASESLIMBARBAT	130
SG CASESLIMBARBAT	87
SG CASESLIMPARBAT	130
SG CASESLIMPARBAT	130
SG CASESLIMPARBAT	75
SG CASESOLPAR60	130
SG CASESOLPAR60	42
SG CASESOLPAR150	130
SG CASESOLPAR150	43
SG CASESTUDIOP	130
SG CASESTUDIOP	33
SG CASESTUDIOP	34
SG CLBEAM7RKIT	64
SG CLBEAM7R	64
SG CLBEAM100	62
SG CLSPOT100	61
SG CLWASHKIT	63
SG CLWASH	63
SG CVMBATI4DLH	81
SG CVRBATI4DLH	81
SG CVWBATI4DLH	81
SG DMX3CLU02	118
SG DMX3CLU03	118
SG DMX3CLU05	118
SG DMX3CLU010	118
SG DMX3LU01	118
SG DMX3LU02	118
SG DMX3LU03	118
SG DMX3LU05	118

CODE	PAG
SG DMX3LU10	118
SG DMX5CLU02	118
SG DMX5CLU03	118
SG DMX5CLU05	118
SG DMX5CLU010	118
SG DMX5LU01	118
SG DMX5LU02	118
SG DMX5LU03	118
SG DMX5LU05	118
SG DMX5LU10	118
SG FASTER4	102
SG FASTER6	103
SG FASTER192N	98
SG FASTER384	99
SG FASTER1224	100
SG FASTER2448	101
SG FASTERSP8	104
SG FLBATCHBOX	45
SG FLBATCHBOX	46
SG FLBATQ1	46
SG FLBATQ3	45
SG H300	106
SG H1500	52
SG HALOFCWM60	29
SG HALOFCWM	28
SG HALOFCW	27
SG HALOFWWM60	29
SG HALOFWWM	28
SG HALOFWW	27
SG HALOPCW1528	30
SG HALOPCW2045	31
SG HALOPCWM60	32
SG HALOPWW1528	30
SG HALOPWW2045	31
SG HALOPWWM60	32
SG HS200	108
SG HS900	53
SG HTZLEDCOBC	79
SG HTZLEDCOBW	78
SG HTZLEDC	77
SG HYH900	107
SG HZRFLD5	115
SG IPCDLU3	119
SG IPCDLU05	119
SG IPCDLU10	119
SG IPCPDLU3	119
SG IPCPDLU5	119

ALPHABETICAL INDEX

CODE	PAG
SG IPCPDLU10	119
SG IPCPLU3	119
SG IPCPLU5	119
SG IPCPLU10	119
SG IPLED9C	16
SG IPLED24C	15
SG IPLED32CBN	14
SG IPLED32CDL	14
SG IPLEDBAR8BAT	20
SG IPLEDBAR12C	17
SG IPLEDBAR24CCODE	18
SG IRIS	131
SG IRIS	131
SG IRIS	131
SG IRIS	131
SG IRISJ	131
SG IRISJ	131
SG IRISM	131
SG IRISM	131
SG IRISM	131
SG JNRPROCW	26
SG JNRPRORGBW	
SG JNRPROWW	26
SG LEDKITHP3BAT	93
SG LEDKITHP3C	94
SG LEDKITHP7BAT	95
SG LEDKITHP7	96
SG LENS14J	131
SG LENS14J	131
SG LENS19	131
SG LENS19C	131
SG LENS19J	131
SG LENS19J	131
SG LENS19M	131
SG LENS26	131
SG LENS26C	131
SG LENS26J	131
SG LENS26J	131
SG LENS26M	131
SG LENS36	131
SG LENS36C	131
SG LENS36J	131
SG LENS36J	131
SG LENS36M	131
SG LENS50	131
SG LENS50C	131

CODE	PAG
SG LENS50M	131
SG LTUHP190W	117
SG LTUHP200W	117
SG LTVIP280W	117
SG MIMETIKM	109
SG MIMETIKXL	110
SG PIXI5	89
SG PIXI5WL	91
SG PIXI5W	90
SG PL300LK	117
SG PL700LK	117
SG PL700LK28	117
SG PLHRI100	117
SG PLHRI132	117
SG PLHRI230	117
SG PLHRI280	117
SG QUARIUXCW	13
SG QUARIUXRGBL	13
SG QUARIUXRGBLZ	13
SG QUARIUXRGB	13
SG QUARIUXRGBW	13
SG QUARIUXRGBWZ	13
SG QUARIUXRGBZ	13
SG QUARIUXVW	13
SG QUARIUXWW	13
SG QUARTZ100	6
SG QUARTZ300KIT	5
SG QUARTZ300	5
SG QUIVER	49
SG QUIVERWI2	49
SG QUIVERWI	49
SG QUIVERX	50
SG SAGOLEDWCW230	23
SG SAGOLEDWCW300	22
SG SAGOLEDWCM	25
SG SAGOLEDW	24
SG SAGOLEDWW230	23
SG SAGOLEDWW300	22
SG SAGOLEDWWM	25
SG SAGOLEDWW	24
SG SLIMBAR8BAT	87
SG SLIMBAR8DL	84
SG SLIMBAR12P	83
SG SLIMBAR16DL	85
SG SLIMBAR240	86
SG SLIMPAR6BAT	75
SG SLIMPAR7DL	66

CODE	PAG
SG SLIMPAR12DL	67
SG SLIMPAR12	68
SG SLIMPAR18C	70
SG SLIMPAR18	69
SG SLIMPARCOB30	72
SG SLIMPARCOB60	73
SG SLIMPARCOB100	74
SG SLIMPARFLC	71
SG SMKFLD5D	115
SG SMKFLD5L	115
SG SMKFLD5M	115
SG SMTBEAM	58
SG SMTDOT	57
SG SMTSPOTPLUS	60
SG SMTWHPLUS	59
SG SOLPARC60BN	131
SG SOLPARC60BN	42
SG SOLPARC60Z	42
SG SOLPARC150BN	131
SG SOLPARC150BN	43
SG SOLPARC150Z	43
SG STUDIOPCW	34
SG STUDIOPRGB	33
SG STUDIOPWW	34
SM300LU5	119
SM300LU10	119
SM300LU15	119
Structure and cabinet	14
Weight and Dimensions:	14



SAGITTER

is a brand of

PROEL SPA

(Worldwide Headquarters)

Via alla Ruenia, 37/43

64027 Sant'Omero (TE) - ITALY

Tel. +39 0861 81241

Fax +39 0861 887862

P.I. 00778590679

N.Reg.AEE IT 08020000002762

sagitter.com

